



BT 400-46



Installation – Operation Maintenance Instructions And Parts List

READ INSTRUCTIONS PRIOR TO STARTING HEATERS



WARNING!

EXPLOSION HAZARD

Do not operate heater in explosive vapor area.

EXHAUST FUMES

Do not operate heater in enclosed spaces. Adequate ventilation is required to prevent buildup of exhaust fumes which can be toxic in concentrated amounts.

DIESEL

Diesel used in operating this heater is explosive.

- **Do not refuel during operation.**
- **Avoid open flame near fuel tank filler neck.**
- **Make sure fire extinguisher is in easy reach.**

HIGH TEMPERATURE

Heat exchanger casing, muffler, exhaust hose, and exhaust stack may become

Dangerously hot.

- **Do not touch heater parts during or immediately after operation.**
- **Perform maintenance only after heater has cooled.**

I



WARNING!

CARBON MONOXIDE

Exhaust gases from the combustion chamber and diesel engine contain poisonous carbon Monoxide gas. Exhaust stack must always be properly installed during operation of Heater to prevent exhaust gases from entering intake.

ELECTRICITY

Shock or injury may result from working on electrical components. Disconnect battery before performing any repairs.

ROTATING PARTS

Serious injury may result from contact with rotating parts. Stand free of moving parts and possible pinch points prior to start-up and during operation.

NOISE HAZARD

Wear approved ear protection equipment within 10 feet (3.05 meters) of operating heater. Failure to do so may result in impairment or loss of hearing.

COMPRESSES AIR

Death or severe injury might result when compressed air is used to blow dirt from skin or clothing. Air entering body openings is extremely dangerous. Compresses air used for cleaning shall not exceed 30 psi (210 KPA). Use goggles or face shield for eye protection.

II



Table of Contents



SECTION 1 _____ **PAGE 1**

INTRODUCTION

- 1.1 General
- 1.2 Scope
- 1.4 Safety Precautions

SECTION 2 _____ **PAGE 2**

- 2.1 General
- 2.2 Scope
- 2.3 Power Unit
- 2.5 Fuel System
- 2.7 Heat Exchanger
- 2.9 Cabinet
- 2.11 Trailer
- 2.13 Specifications

SECTION 3 _____ **PAGE 6**

PREPARATION FOR USE AND STORAGE

- 3.1 General
- 3.2 Scope
- 3.4 Preparation for use
- 3.6 Preparation for storage

SECTION 4 _____ **PAGE 8**

OPERATING INSTRUCTIONS

- 4.1 General
- 4.2 Scope
- 4.4 Theory of Operation
- 4.6 General Theory
- 4.11 Detailed Theory
- 4.12 Fuel System
- 4.13 Fuel System
- 4.15 Burner Control Valve
- 4.18 Fuel Atomizing Head
- 4.20 Temperature Selector Valve
- 4.23 Temperature Selector Indicator Knob
- 4.26 Electrical System
- 4.28 Operating Instructions
- 4.31 Operating Under Normal Circumstances
- 4.34 Operating Under Extreme Cold Conditions

III

AEROTECH HERMAN NELSON INTERNATIONAL INC.
100 Eagle Drive, Winnipeg, Manitoba Canada R2R 1V5
Phone: 204-633-1999 (24 Hours) Fax: 204-694-1612 Email: sales@hermannelson.com

www.hermannelson.com

06.19.09 REVISION 1.03



Table of Contents



SECTION 5 _____ **PAGE 22**

MAINTENANCE INSTRUCTIONS

- 5.1 General**
- 5.2 Scope**
- 5.4 Cleaning**
- 5.6 Flexible Ducts**
- 5.8 Lubricating**
- 5.10 Inspection and Preventive Maintenance**
- 5.12 Battery**
- 5.18 Fuel Filter**
- 5.20 V-Belt**
- 5.24 Heat Exchanger Assembly**
- 5.29 Fan and Mounting Ring Assembly**
- 5.36 Heat Exchanger**
- 5.41 Carbon Monoxide Test**
- 5.42 Heater Ignition System**
- 5.44 Coil**
- 5.46 Igniter Cable and Igniter Plug**
- 5.51 Fuel Pump**
- 5.67 Troubleshooting**

SECTION 6

PAGE 39

SECTION 7

PAGE 83

ALPHAMERIC INDEX

IV



Table of Contents



PARTS LIST

LIST OF ILLUSTRATIONS:

FIGURE NO.	TITLE	PAGE
2-1	Heater Fuel System	2
2-2	Sectional View of Nozzle and Combustor	4
4-1	Control Panel Components	9
4-2	Schematic Diagram of Fuel Pump	10
4-3	Burner Control Valve	12
4-4	Fuel Atomizing Head	13
4-5	Temperature Selector Valve	15
4-6	Heater Electrical System Circuit	16
4-7	Duct Attachments	19
4-8	Fuel Gauge and Flame Window Location	20
5-1	Fuel Pump Mounting Bracket	27
5-2	Nozzle and Combustor	30
5-3	Igniter Plug Adjustment Points	31
5-4	Valve and Block Assembly	32
5-5	Pump Pressure Testing Assembly	33
5-6	Fuel System Air Leak Testing	35

LIST OF TABLES:

TABLE NO.	TITLE	PAGE
2-1	Specifications	3
2-2	Fuel Specifications and Requirements	3
4-1	Control and Indicator Locations and Use	9
5-1	Lubrication Instructions	23
5-2	Inspection, Checks and Services	24
5-3	Troubleshooting Chart	37

V



Section 1 • Introduction



1.1 General

1.2 Scope

1.3 These instructions are for use by personnel to whom the BT400-46 heater manufactured by **AEROTECH HERMAN NELSON INC.** has been issued. They contain the information on the operation and maintenance of the heater as well as the description of the major units and their functions in relation to other components of the heater. In addition, a list of parts which may be required for maintaining the heater, is provided in Section 6.

1.4 Safety Precautions

1.5 Precautionary measures to be taken during operation and maintenance of the heater are contained in the appropriate paragraphs of the manual. In addition, all safety precautions are listed in the front of this manual.

1.6 Below is a list of definitions to terms commonly used in this book.

DANGER: You will be subject to serious injury or death if you fail to follow instructions!

WARNING: You could be subject to serious injury or death if you fail to follow instructions!

CAUTION: You can be hurt if you fail to follow instructions!

NOTICE: Your heater or other property could be damaged if you fail to follow instructions!



Section 2 • Description



2.1 General

2.2 The model BT400-46 heater is a fully enclosed, portable, two wheel, trailer mounted unit, intended for use in ground heating maintenance shelters, portable hangers, aircraft engines and fuselages, and other similar enclosures.

2.3 Power Unit

2.4 The model BT400-46 heater is supplied with a variety of diesel engines. A drive coupling is attached to the drive shaft of the engine and is attached to a driven coupling by way of a flexible rubber sleeve. The driven coupling drives the heater fan through a pulley, a V-belt drives the fuel pump.

2.5 Fuel System

2.6 The fuel system supplies a variety of fuel to the heater and the engine. Fuel is drawn from a removable 35 gallon fuel tank through an automotive type fuel filter (see figure 2-1) by a belt-driven fuel pump. Fuel flows through the nozzle contained in a holder with Inlet and bypass fuel lines. As the fuel leaves the nozzle it is atomized and ignited by the igniter plug. Fuel is also bypassed from nozzle, through a check valve, to the temperature selector valve on the control panel. The check valve prevents a reverse flow.

Figure 2-1 • Heater Fuel System

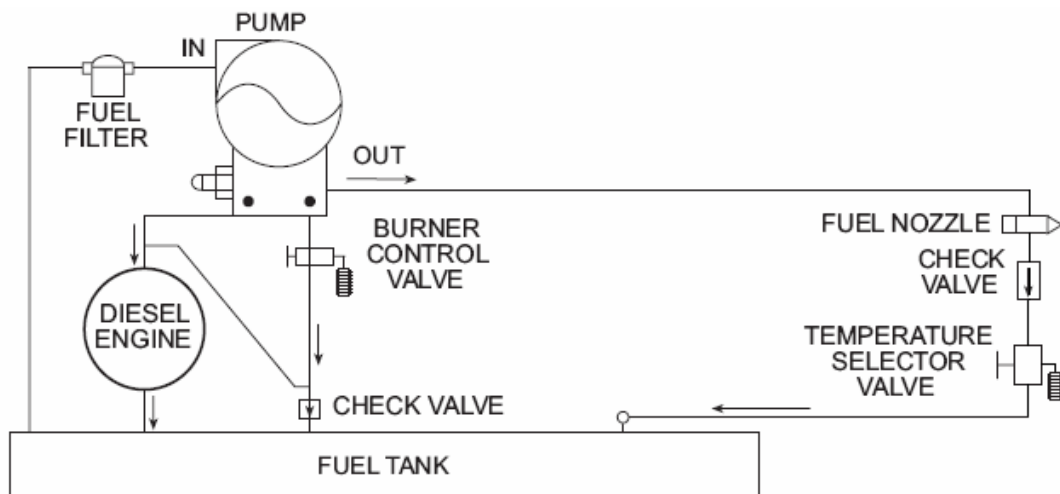



Table 2-1 • Specifications



LENGTH	74" inches
HEIGHT	44" inches
WIDTH	54" inches
SHIPPING WEIGHT	800 lbs
ENGINE	See supplement
HEATED AIR OUTLET	12" inches diameter
EXHAUST OUTLET	5" inches diameter
RATING	400,000 BTUH @ -65°F (-54°C) ambient
AIR OUTLET RANGE	150 TO 280°F (66 to 138°C) maximum
AIR DELIVERY RATE	1500 CFM @ 280°F (138°C) maximum
FUEL TANK CAPACITY	35 gallons (132.5 liters)
ELECTRICAL	12 volts, negative ground
BATTERY	Group 12H
FUEL	See Table 2-2
ENGINE LUBRICANT	0W-30

Table 2-2 • Fuel Specifications & Requirements



AMBIENT TEMPERATURE	SPECIFICATION	SYMBOL/ NOMENCLATURE	REMARKS
-65°F (-54°C) & ABOVE	MIL-T-5624	JP-4-AIRCRAFT TURBINE FUEL	PRIMARY FUEL
-50°F (-46°C) & ABOVE	MIL-T-5624	JP-5-AIRCRAFT TURBINE FUEL	ALTERNATE FUEL
-40°F (-40°C) & ABOVE	MIL-T-83133	JP-8-AIRCRAFT TURBINE FUEL	ALTERNATE FUEL
+20°F (-7°C) & ABOVE	W-F-800	DF-2-DIESEL FUEL	ALTERNATE FUEL
-25°F (-32°C) & ABOVE	W-F-800	DF-2-DIESEL FUEL	ALTERNATE FUEL
-60°F (-51°C) & ABOVE	W-F-800	DF-2-DIESEL FUEL	ALTERNATE FUEL



**Figure 2-2 • Sectional View of
Nozzle & Combustor**

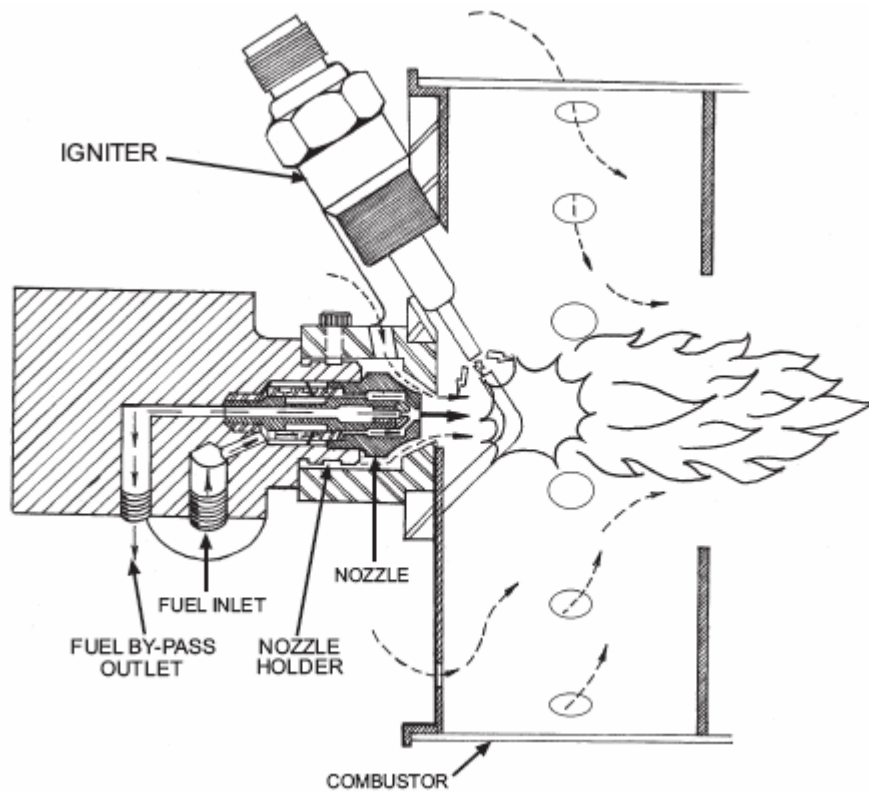

2.7 Heat Exchanger

2.8 Fuel flowing from the nozzle is ignited in the combustor (see figure 2-2). The burning fuel strikes a plate or target in the combustor and is diffused into the heat exchanger. Air from the fan enters holes in the side of the combustor in a manner that will ensure proper fuel-air mixture. The burning fuel flows through the heat exchanger in a spiral path between the surfaces of the ventilating air tubes and is expelled through the exhaust opening at the top of casing. Ventilating or heating air is forced through the parallel tubes and the space between the heat exchanger shell and the casing. A damper control, which is locked by a handwheel mounted in a slot above the discharge end of the heater, is used to reduce heat output, by reducing the air volume without reducing the temperature. Volume can be set between full and one-half or full volume.



Section 2



2.9 Cabinet

2.10 The power unit is enclosed in a cabinet which provides protection against the elements and prevents damage during storage or transit. The cabinet is hinged to provide access to the power unit and all other controls for easy maintenance.

2.11 Trailer

2.12 A two-wheeled trailer is provided to transport the heater from worksite to worksite. Duct holders hold the ducts when not in use. An adjustable tow bar serves as a support when the trailer is at rest. Do not exceed 20 mph when towing.

2.13 Specifications

2.14 The BT400-46 heater specifications are listed in *Table 2-1*.



Section 3 • Preparation for Use & Storage



3.1 General

3.2 Scope

3.3 The heater unit is shipped as a pre-tested, completely assembled unit. There are, however, certain steps which shall be taken prior to putting the unit into operation or storage.

3.4 Preparation for use

3.5 To prepare the heater for use proceed as follows:

- (a) Remove all crafting, blocking, and protective material from heater.

! CAUTION !

**Do not use forklift to move heater.
This could cause damage to unit.**

- (b) Check action of parking brake and set brake to prevent heater from rolling.
- (c) Inspect unit for any damaged gauges, meters, valves, loose connections or mountings, loose or missing hardware, frayed insulation on wiring, or any other damage.
- (d) Check drive V-belt for proper tension and condition.
- (e) Using a hydrometer, check each battery cell for a specific gravity of 1.250 or higher. Ensure electrolyte level is 1/4 inch to 1/2 inch above the top of the battery plates.

! WARNING !

Use protective clothing, face shield, rubber gloves and apron when servicing battery.

! WARNING !

**Do not smoke or use an open flame in heater vicinity while servicing the fuel tank.
Failure to comply may result in serious injury or death.**

- (g) Remove fuel tank filler cap and fill tank to capacity with recommended fuel.
Replace filler cap.
- (h) Check engine oil level.
- (i) Ensure tire pressure is 20 psi max.



Section 3 • Preparation for Use & Storage



3.6 Preparation for Storage

3.7 To prepare heater for storage proceed as follow:

- (a) Drain fuel from tank
- (b) Replace fuel filter with a new filter.
- (c) Disconnect and remove battery from heater.

! WARNING !

**Use protective clothing, face shield, rubber gloves and apron
when removing battery from heater.**

- (d) Replace fuel nozzle.



Section 4 • Operation instructions



4.1 General

4.2 Scope

4.3 This section describes the theory of operation, operating controls and indicators and the operative procedures for the heater.

4.4 Theory of Operation

4.5 The description will be presented in two parts; (1) General Description and (2) Detailed Description. The general description explains the interrelationship of functional components at an operation level. Functions of individual components and unique assemblies are given in the detailed description.

4.6 General Theory

4.7 Fuel is drawn from the fuel tank through the fuel filter and delivered under constant pressure to the variable discharge combustion nozzle (**see figure 2-1**). Fuel pressure causes the temperature selector valve to open and bypass a metered amount of fuel back to the fuel tank. The ignition system produces a high voltage spark at the igniter plug to ignite the fuel and air mixture. The resultant flame heats the heat exchanger. Ambient air is forced through the heat exchanger by the fan assembly. As the ambient air passes through the heat exchanger it is directed through the heat deflector to the heat exchanger outlet.

4.8 As the heated air leaves the heat exchanger outlet, it passes over the temperature selector valve and burner control valve sensing elements. The air temperature detected by the temperature selector valve's sensing elements determines the amount of fuel that is bypassed to the fuel tank thus maintaining the desired output air temperature. In the event of a high output temperature, the burner control valve sensing elements detects this condition and turns off the burner.

4.9 Electrical System

4.10 A battery supplies power for the heater control circuits. A toggle switch on the control panel turns on the panel light for night time illumination. To start the diesel engine a momentary switch is moved to and held in the closed position providing a circuit to energize the starter solenoid. The starter solenoid closes making a circuit from the battery to the starter motor. For cold-weather starting a momentary switch is moved to and held in the closed position providing a circuit for the preheater relay. The preheater relay closes providing a circuit for the preheater which warms the air entering the diesel engine. An oil pressure switch closes and remains closed during engine operation unless oil pressure is lost. Power for the hourmeter is provided through the oil pressure switch, thus being energized during engine operation to record the total operating time. During engine operation a flywheel alternator produces a voltage which is maintained by the voltage regulator at a suitable potential for recharging of the battery.

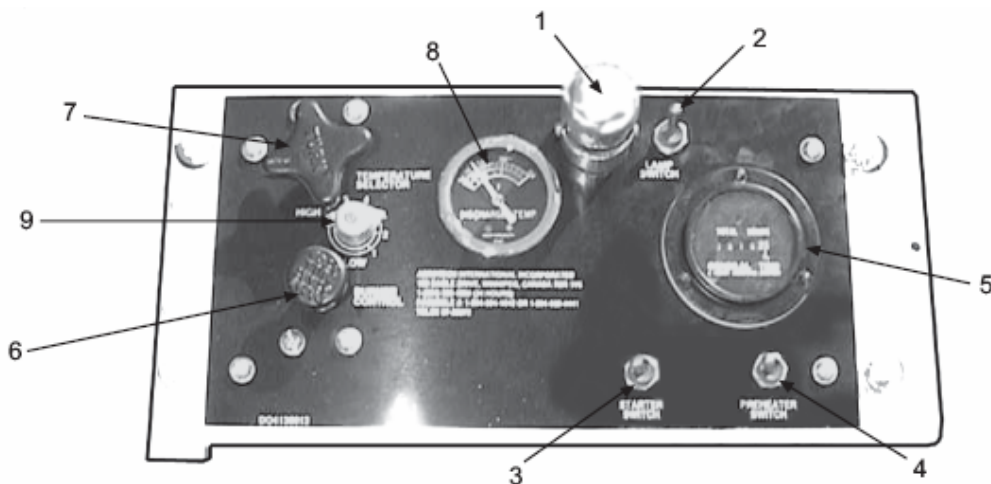

Table 4-1 • Control & Indicator Location and Use



FIGURE AND ITEM	CONTROL OR INDICATOR	DESCRIPTION AND USE
FIG 4-1-1	PANEL LAMP	Night time illumination of control panel
FIG 4-1-2	LAMP SWITCH	Turns panel lamp on and of
FIG 4-1-3	STARTER SWITCH	Momentary switch when in “on” position energizes starter motor
FIG 4-1-4	PREHEATER SWITCH	Momentary switch when in “on” position energizes starter preheater
FIG 4-1-5	HOURMETER	Indicates total hours of engine operation
FIG 4-1-6	BURNER CONTROL VALVE	Depressive valve engages burner
FIG 4-1-7	TEMPERATURE SELECTOR VALVE	Rotating knob clockwise increases discharge temp. Rotating knob counterclockwise decreases temp.
FIG 4-1-8	DISCHARGE TEMPERATURE INDICATOR	Indicates discharge temperature in degrees F
FIG 4-1-9	TEMPERATURE INDICATOR KNOB	Indicates approximate temperature range

Figure 4-1 • Control Panel Components





Section 4



4.11 Detailed Theory

4.12 Fuel System

4.13 Fuel Pump

4.14 The fuel pump is mounted on a bracket to the left of the engine. The pump is belt driven by the diesel engine. The pump has three outlets (see figure 4-2). A primary by-pass will handle all the flow if the balanced valve is closed. If the primary by-pass line is closed, the fuel will flow into the balanced valve and hence out through both the nozzle fuel line and the secondary by-pass line. The secondary by-pass supplies fuel to the diesel engine and returns surplus back to the fuel tank. The burner control valve, which is in the primary by-pass line, is closed to obtain fuel flow to the nozzle. When this valve is open the pump can not build up sufficient pressure to open the balanced valve and effect flow through the nozzle fuel line. Closing the burner control valve allows the pump to build up pressure to the point where the valve opens allowing fuel flow in the nozzle fuel line. The pressure at which the balanced valve opens is determined by the compression of the piston spring, normally the spring is adjusted to 150 psi. This pressure can be checked at the burner control valve. Since the pump delivers fuel in excess of the maximum nozzle capacity there will always be flow through the secondary by-pass line when burner control valve is on. Fuel from the secondary by-pass flows back into the tank through a check valve which opens under a pressure of about 5 psi, which is sufficient to divert adequate fuel to the engine.

Figure 4-2 • Schematic Diagram of Fuel Pump

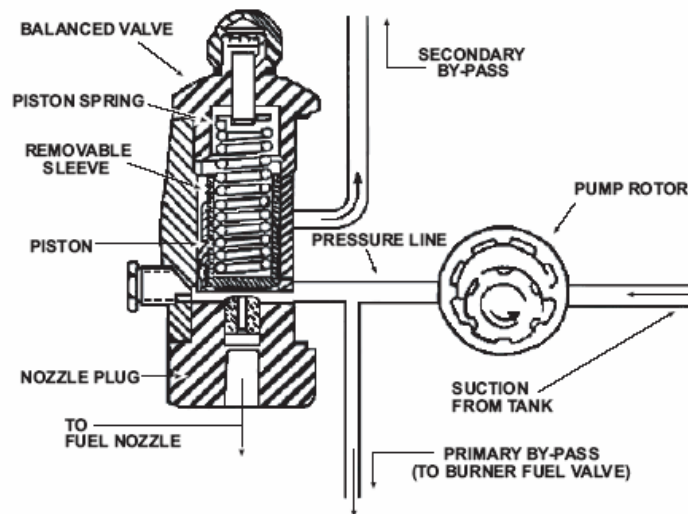



Section 4



4.15 Burner Control Valve

- 4.16** The burner control valve (see figure 4-3) is not intended for manual heat regulation, the manual control knob serving only to either full close (burner on) or fully open (burner off) the primary by-pass line which returns fuel back to the tank. Pressing the knob downward seats a ball which seals the inner axial passage leading to the fuel outlet. At the same time, fuel under pump pressure flows into the area over the diaphragm, forcing the diaphragm downward against the loading spring. This allows the push pins to drop so that the pressure balancing spring may force the movable sleeve downward to hold the ball firmly in its seat, closing the outlet passage. Thus the fuel pressure acts to keep the valve closed. Lifting the knob raises the movable sleeve, permitting the lower plunger to be in turn raised by the plunger spring, freeing the ball from its seat. Fuel then flows through the inner valve body to the outlet. This relieves the fuel pressure on the diaphragm and the valve returns to the open position.
- 4.17** The burner control valve also serves as an overheat protection safety valve. This is achieved through the action of a sensing element in the discharge air system. When the discharge air temperature exceeds safe limits (about 350°F), the thermostatic medium in the sensing element will expend sufficient pressure to assist the loading spring so that together they force the diaphragm upward, opening the valve. This turns off the burner. The valve will not close again to permit subsequent burner operation until operated manually.



Figure 4-3 • Burner Control Valve

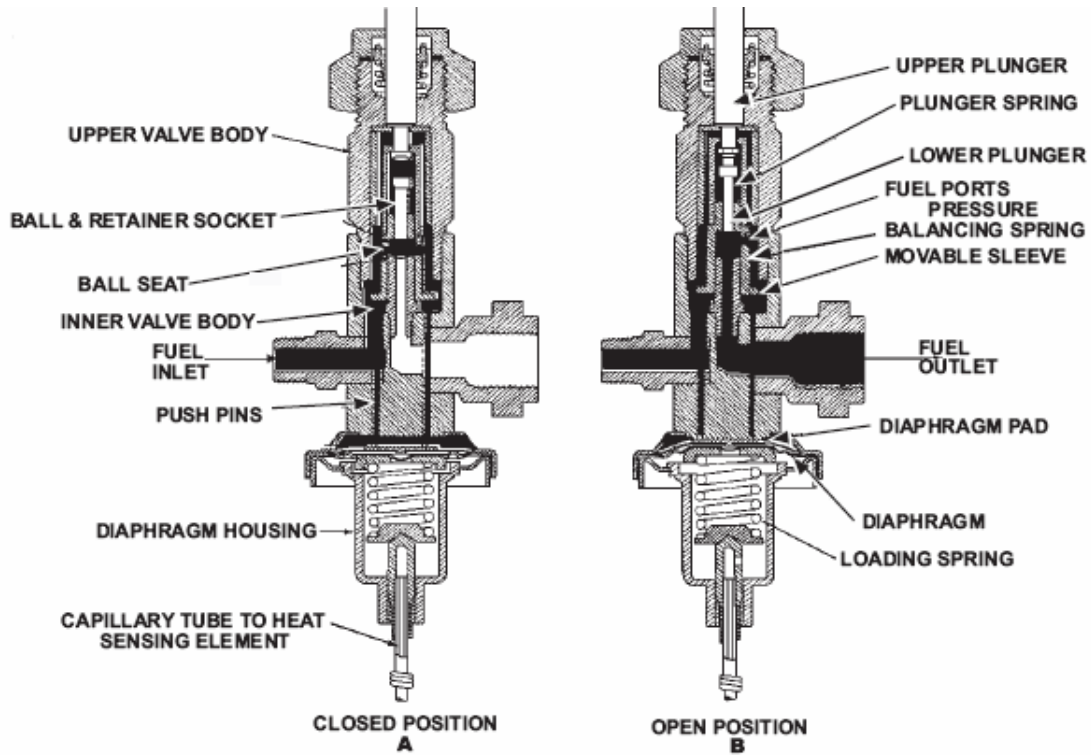



Section 4



! CAUTION !

Beware of chips – Pipe, tubing and valve ends must be clean. System contaminants in any valve can foul valve seats and cause leakage. Back flush systems before putting in service whenever possible. Install screen or filters where required to protect valves. Pipe Dope – Goes on male thread carefully so nothing gets in valve and system. Strings of tape type sealants can foul valve seats.

4.18 Fuel Atomizing Head

4.19 The fuel nozzle screws into a nozzle holder, the combination being known as the fuel atomizing head. Fuel from the inlet line enters the nozzle supply chamber through a strainer screen (see figure 4-4), then flows through slots in the inner had through which impacts a whirling motion to the fuel so that it partially atomizes as it enters the swirl chamber. Atomization is completed as the fuel sprays through the discharge orifice into the combustor. A portion of the fuel is also forced into a by-pass chamber which leads to the by-pass outlet passage in the nozzle holder. A check valve connected between the outlet and by-pass fuel line prevents a reverse fuel flow to the nozzle from the by-pass line. Fuel is discharged from the nozzle at a fixed continuous rate and a continuous fixed flame is obtained. Changes in heat output is obtained by varying the volume of fuel discharged from the nozzle. This is accomplished indirectly by controlling the amount of fuel flowing through the by-pass fuel line through the action of the temperature selector valve.

Figure 4-4 • Fuel Atomizing Head

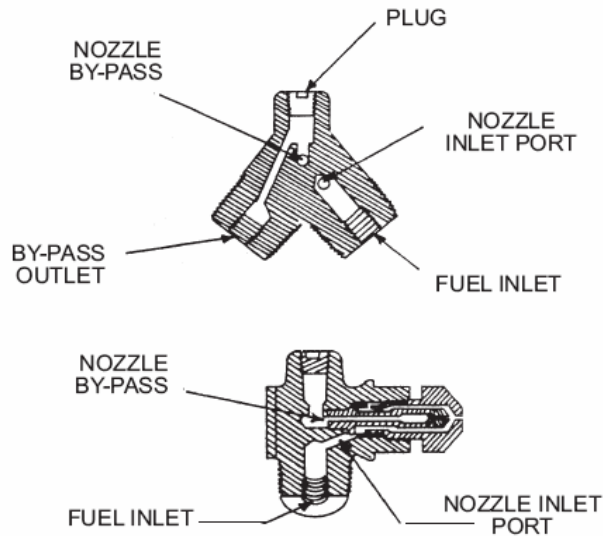



Section 4



4.20 Temperature Selector Valve

4.21 Manual adjustment of the temperature selector valves within the operating range (150°F to 280°F) applies motion through a pressure cone (see figure 4-4) to an inverted spring cup which forms the holder for the needle assembly. The resulting movement of the needle seat orifice gives a smooth, continuous regulation of fuel flow throughout the normal operating temperatures. A similar control of fuel is obtained by upward and downward movement of the diaphragm. The diaphragm is spring loaded to the point where a very slight additional upward pressure will result in further opening of the valve and increase the flow of fuel in the by-pass line. This additional pressure is supplied by the expansion of the thermostatic medium in the heat sensing element located in the discharge air stream. This pressure applied to the heat sensing element located in the discharge air stream. This pressure applied to the diaphragm balances the fuel flow to the selected temperature.

4.22 Adjustment of the valve for any discharge temperature results in an initial fuel discharge greater than needed to maintain the selected temperature. The resulting increased heat output of the combustor brings the heater up to the selected temperature rapidly. As the discharge temperature rises, the action of the temperature sensing element opens the valve further, increasing the fuel flow in the by-pass line, thereby decreasing the nozzle fuel discharge, consequently reducing the combustor heat output. The discharge air temperature overshoots the selected temperature, then cycles about this temperature until a stable condition is reached. Selecting a new temperature results in the same type of hunting action until stabilizing at the new temperature.

4.23 Temperature Selector Indicator Knob

4.24 The temperature selector indicator knob is mounted on the control panel next to the temperature selector knob. The approximate temperature is indicated by the pointer. When the temperature selector knob is rotated, a pinion on the shaft engages a pinion on the temperature selector indicator knob shaft and rotates the knob in direct relationship to the temperature selector valve.



Figure 4-5 • Temperature Selector Valve

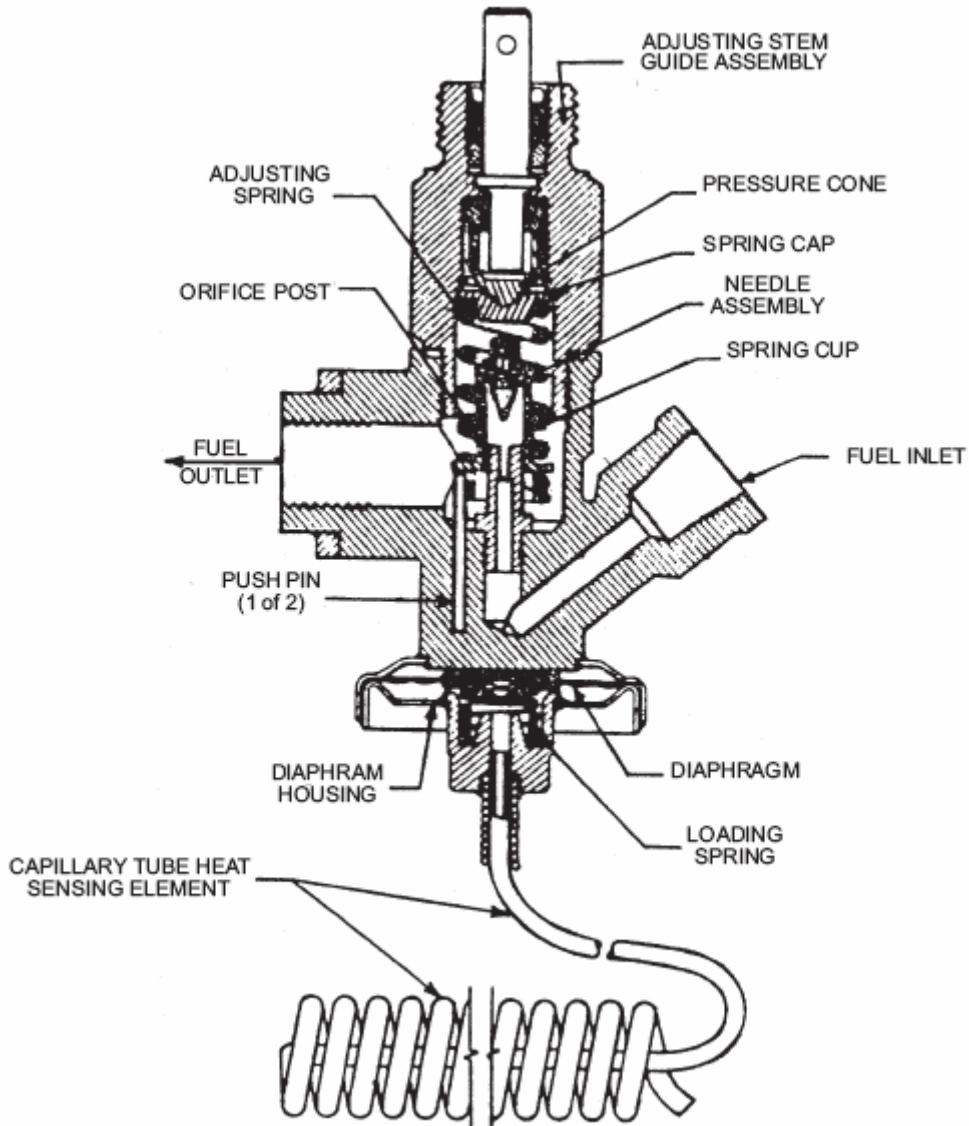



Section 4



- 4.25 The range is from low corresponding to a discharge temperature of approximately 150°F to a high corresponding 280°F. Each number represents approximately 25°F with 150°F being close to number “1” on the control panel.

Figure 4-6 • Heater Electrical System Circuit Diagram

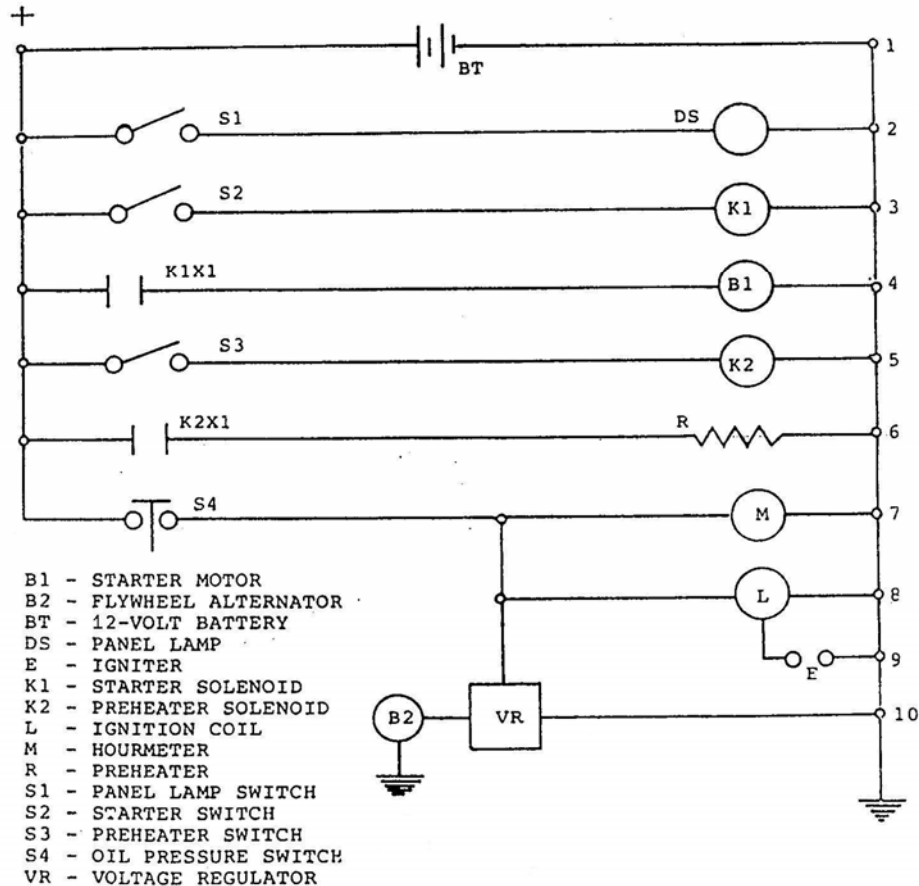



Section 4



4.26 Electrical System

4.27 Refer to figure 4-6 for the following description of the electrical system for this unit.

- (a) A 12 VOLT battery (BT) supplies power for all control circuits. Battery negative corresponds to system electrical ground similar to most automotive systems.
- (b) A toggle switch (S1) on the control panel turns on the panel light (DS) for nighttime illumination of controls on the panel.
- (c) A momentary switch (S2) is moved to and held in the closed position to start the diesel engine.
- (d) Closing S2 provides a circuit to energize the starter solenoid (K1). Its contacts (K1X1) close providing a circuit from the battery to the starter motor (B1).
- (e) For cold weather starting a momentary switch (S3) is held in the closed position providing power to the preheater relay (K2). The relay contacts (K2X1) supply power from the battery to the preheater (R).
- (f) The oil pressure switch (S4) closes and remains closed during engine operation. Through S4 the hour meter (M) is energized and record total operating time.
- (g) When S4 closes battery power is provided to the ignition coil (L) which provides a high voltage to produce a continuous arc across gap E to ignite the fuel.
- (h) During engine operation the alternator (B2) produces a voltage which is maintained by the voltage regulator (VR) to recharge the battery through the oil pressure switch (S4).

! WARNING !

The BT400-46 heater is unsafe for operation in explosive atmospheres.

4.28 Operating Instructions

4.29 Preliminary Adjustments

4.30 Before starting the heater proceed as follows:

- (a) Tow trailer to site and select a location as close to level as possible. Out-of-level should not exceed 8 1/2 degrees.
- (b) Set parking brakes.
- (c) Perform all inspection checks and services as listed in section 5, table 5-2.

! WARNING !

Exhaust gases from the combustion chamber and the diesel engine contain poisonous carbon monoxide gas. It is possible to contaminate the ventilating air with exhaust gases if these gases are drawn into the air inlet. The heater should be positioned so that the wind blows the exhaust gases away from the air inlet. Before operating the heater, insure the exhaust muffler from the diesel engine is free of leaks.



Section 4



- (d) Remove exhaust cover and place exhaust stack over exhaust pipe. If additional exhaust pipe is desired, use same size of pipe as used on the heater or larger. NEVER REDUCE PIPE SIZE. Limit length of exhaust pipe to 20 feet. Longer pipe runs may cause condensation of exhaust gases and other complications. All pipe joints must be tight. Pitch any connecting stack or pipe upward at least one foot elevation for every ten foot run.

! WARNING !

If heater is operated inside a building, the exhaust gases will be conducted to the outside by means of an extension pipe. Failure to comply may result in death or serious illness.

- (e) Remove air outlet cover and attach flexible ducts. A 12 inch flexible duct can be attach directly to the duct connector at heat exchanger air outlet (see figure 4-6). For 6 inch flexible ducts, install a 6 to 12 duct adaptor on duct connector, or at the end of a 12 inch duct.

NOTE

Kinks in the air ducts impede air flow. Spread out ducts so as to avoid sharp bends or kinks.



Figure 4-7 • Duct Attachment

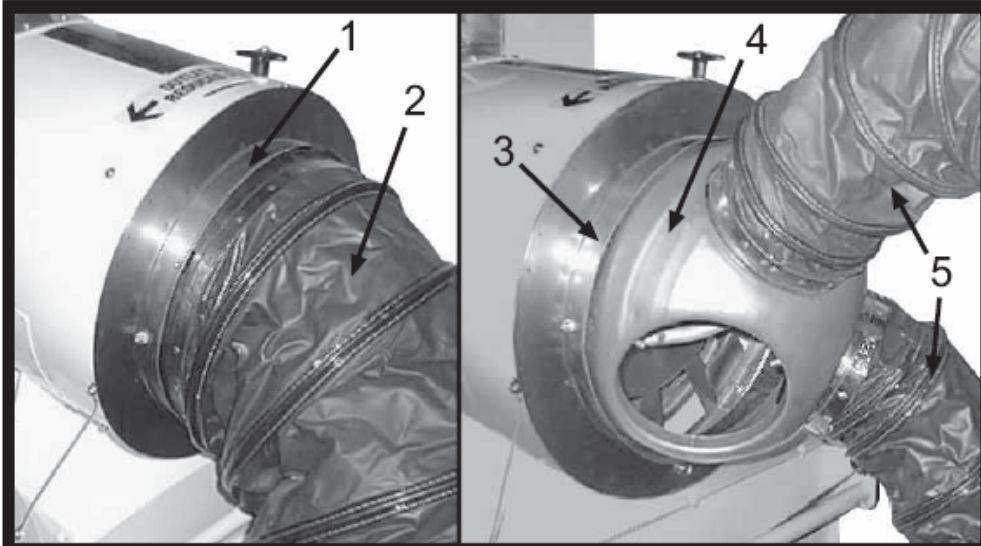

- 1 • Adapter Assembly (12" inch)
- 2 • 12-Inch Duct
- 3 • Adapter Assembly (12" inch)
- 4 • Duct Adapter (6" inch)
- 5 • 6-Inch Duct (3 required)



- 6 • 12-Inch Duct
- 7 • 6-Inch Duct (3 required)
- 8 • Duct Adapter (6" inch)



Section 4



4.31 Operating Under Normal Conditions

4.32 Start Up

4.33 To set the heater into operation proceed as follows:

- (a) Open control panel access door.
- (b) Ensure temperature selector indicator knob is pointing to number “1” on the control panel.
- (c) Move engine stop-run lever to the “**RUN**” position.
- (d) Move and hold the engine start switch in the “**ON**” position until the engine fires.

NOTE

New heaters and heaters with newly overhauled engines may require several seconds to start while air in the fuel lines are being purged.

- (e) Allow engine to run for two minutes or until running smooth.
- (f) Push down on burner control valve while looking through the flame view window (see figure 4-7). Ensure that the fuel ignites. Release burner control valve ten seconds after flame starts. Ignition should continue.
- (g) Adjust temperature by rotating the temperature selector knob slowly clockwise until desired temperature is obtained.

NOTE

Due to the lag in the operation of the temperature valve, a few minutes are required for a full indication of the outlet air temperature.

Figure 4-8 • Fuel Gauge & Flame Window Locations

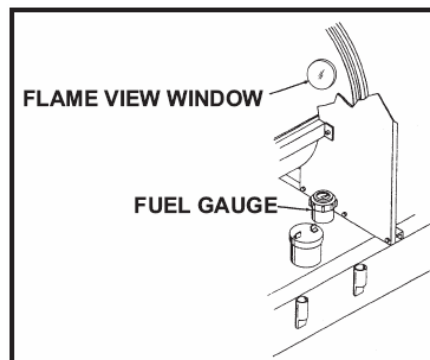

20



Section 4



4.34 Shut Down

4.35 To shut down the heater after operation proceed as follows:

- (a) Rotate temperature selector valve counterclockwise until temperature selector indicator knob indicates “LOW” on control panel.

NOTE

Do not force temperature selector valve stem against stop

- (b) Pull up on burner control valve while looking through the flame view window. Ensure flame has extinguished.
- (c) Allow engine to run until temperature gauge points to “COOL”.
- (d) Move the engine stop-run lever to the “STOP” position.

4.36 Operation Under Extreme Cold Conditions

4.37 Start Up

4.38 To set the heater into operation when the ambient temperature is below 5°F (-15°C) proceed as follows:

- (a) Open control access panel.
- (b) Ensure temperature selector indicator knob is positioned to number “1” on the control panel.
- (c) Move engine stop-run lever to the “RUN” position.
- (d) Move and hold the preheater switch to the “ON” position.
- (d) Move and hold the engine start switch in the “ON” position until the engine fires, then release the preheater and start switches.

NOTE

For quicker warm-up, hold the preheater switch “ON” until the engine runs smoothly

4.39 Shut Down Under Extreme Cold Conditions

4.40 Shut down procedures are the same as in paragraph 4.34.



Section 5 • Maintenance Instructions



5.1 General

5.2 Scope

5.3 This section contains instructions for maintaining BT400-46. If performed on a regular basis, will insure proper operation and extend the life of the heater.

5.4 Cleaning

5.5 For access to the heater components for cleaning, proceed as follows:
(a) Open hood.

! Warning !

Compressed air used for cleaning will not exceed 30 psi and then only with approved personnel protective equipment such as safety goggles or face shield.

- (b) Brush dirt and dust from the components with a soft bristle brush. Blow dirt and dust away using dry compressed air.
- (c) Remove corrosion from battery posts and cable clamps using a battery brush. Clean battery with a weak solution of baking soda and warm water. Rinse with clean water. Clean battery tray in the same manner.
- (d) With hood and access doors closed tightly, wash heater using a scrub brush to apply a solution of car wash detergent, or equal, in warm water. Remove the detergent solution with water dispensed from a garden hose. Avoid spraying water directly into the air flow outlet.

5.6 Flexible Ducts

5.7 Wash ducts with soap or detergent and water. Dry with a soft cloth. Ensure ducts are thoroughly dry before putting duct away.

5.8 Lubricating

5.9 Points of lubrication, type of lubrication, application and time interval are listed in **table 5-1**.

5.10 Inspection and Preventive Maintenance

5.11 Preventive maintenance checks, services, and inspections are listed in table 5.2. Checks, services and inspections should be accomplished at time intervals listed in the operational time column.

! Warning !

Never attempt disassembly until heater has been allowed to cool and the battery has been disconnected

22



Table 5-1 • Lubrication Instructions



LUBRICATION POINT	LUBRICANT (SPECIFICATION)	ACTION	INTERVAL
Engine:			daily or 8 hours
Dipstick	Refer to TABLE 2-1	Check oil level, fill to mark	
Crankcase	Refer to TABLE 2-1	Drain and refill	150 hours
Oil Filter Element	See applicable engine supplement	Replace filter element	150 hours
Air Filter	See applicable engine supplement	Check and replace as necessary	150 hours
Frame and Axle Group:			
Access Doors	Light machine oil	Lubricate hinges	150 hours
Wheel Bearings	NLGI #2 grade general purpose lithium 12	Hand pack	1000 hours or 2 years
Control Panel			
Fuel Filter	Filter element	Replace element	300 hours or 3 months



Table 5-2 • Inspection, Checks & Services



COMPONENT OR PART	INSPECTION, CHECK OR SERVICE	OPERATIONAL TIME PERIOD
Heater unit	Visually inspect for loose or missing hardware.	8 hours or daily
Fuel tank	Inspect vent hole, fuel cap and fuel level gauge	8 hours or daily
Air ducts	Inspect for damage or wear. Replace as necessary.	8 hours or daily
Engine crankcase	Check oil level, add oil if necessary.	8 hours or daily
Engine air filter	Check for dirt. Clean if necessary.	8 hours or daily
Batteries	Check electrolyte level, fill to proper level with distilled water.	25 hours or weekly
Pneumatic tires	Check tire pressure; add air if necessary. Check for tire wear.	25 hours or weekly
Air TEMP gauge	Inspect for visible damage.	25 hours or weekly
Exhaust system	Inspect for secure mounting, cracks or dents. Inspect exhaust stack and extensions for damage. Check screen for damage. Clean or replace as necessary.	25 hours or weekly
Burner control valve	Check valve for leakage and operation. Replace a defective valve.	150 hours or monthly
Temperature selector valve	Inspect for visible damage. Check operation. Replace a defective valve.	150 hours or monthly
Fuel filter	Replace filter, refer to FUEL FILTER (paragraph 5.18).	300 hours or 3 months
Engine	Check cooling air inlet openings for dirt. Clean if necessary. Check for damage, corrosion and loose hardware. Retighten hardware as necessary.	300 hours or 3 months
Fuel pump	Clean fuel pump strainer, refer to CLEANING FUEL PUMP STRAINER (paragraph 5.69). Check pump for proper operation and leakage. Replace a defective pump.	300 hours or 3 months
V-belt	Inspect for wear, fraying or stretching, and for proper deflection. Adjust tension, refer to v-belt if necessary.	300 hours or 3 months
Coupling	Inspect for damage. Replace if necessary.	300 hours or 3 months
Fuel lines	Inspect entire fuel system for leaking connections. Tighten as necessary.	600 hours or 6 months
Ignition system	Check system, refer to IGNITION SYSTEM (paragraph 5.42).	600 hours or 6 months
Electrical wiring and cables	Visually inspect for loose connections, damage, and corrosion. Tighten, replace or clean as necessary.	600 hours or 6 months
Burner nozzle	Inspect for carbon deposits or other defects. Clean or replace as necessary.	600 hours or 6 months
Heat exchanger	Inspect for carbon deposits or other defects. Clean or replace as necessary. Refer to HEAT EXCHANGER (paragraph 5.36)	600 hours or 6 months
Heater unit	Inspect for loose or missing hardware and corrosion. Clean entire unit (paragraph 5.4)	600 hours or 6 months
Ventilating air	Perform CARBON MONOXIDE TEST (paragraph 5.40).	600 hours or 6 months



Section 5



5.12 Battery

! Warning !

**Use protective clothing, face shield, rubber gloves and apron
when removing battery**

5.13 Check the specific gravity of each cell using a hydrometer. The specific gravity should be 1.250 or higher. Replace battery if any cell does not meet this condition.

5.14 Battery Removal

5.15 To remove battery, proceed as follows:

- (a) Gain access to battery.
- (b) Disconnect battery cables from battery. Remove negative cable first.
- (c) Remove battery hold down bracket.
- (d) Remove battery.
- (e) Remove battery to shop for servicing.

5.16 Battery Installation

5.17 To install battery, reverse removal procedures.

5.18 Fuel Filter

5.19 The fuel filter element is non-reusable. Replace fuel filter as follows:

- (a) Gain access to fuel filter assembly.
- (b) Remove bolt from top of fuel filter assembly.
- (c) Remove base and gasket.
- (d) Remove element from base.
- (e) Install new element and gasket.
- (f) Install bolt securely to base through top assembly.

5.20 V-Belt

5.21 The v-belt encircles the driven coupling and fuel pump.



Section 5



5.22 V-Belt Adjustment

5.23 To adjust the v-belt, proceed as follows:

- (a) Open hood.
- (b) Loosen the two bolts securing the fuel pump to the fuel pump mounting bracket (see figure 5-1).
- (c) Move the fuel pump to the left to tighten the v-belt. To check the tension, depress the v-belt between the driven coupling and the fuel pump. The deflection should be 1/2 inch with 5 pound force.

5.24 Heat Exchanger Assembly

5.25 Heat Exchanger Assembly Removal

5.26 To remove the heat exchanger assembly, proceed as follows:

- (a) Remove hood assembly by removing the 8 bolts and washers that secure hood to heater. Remove capillary tube cover. Lift hood from heater.
- (b) Remove the 4 bolts from mounting brackets of heat exchanger assembly.
- (c) Remove clamps from flexible exhaust hose and remove hose.
- (d) Remove v-belt by slipping belt from pulleys.
- (e) Remove duct adapter at rear of heat exchanger assembly. Remove sensing elements.
- (f) Remove heat exchanger assembly from trailer assembly.



Figure 5-1 • Fuel System

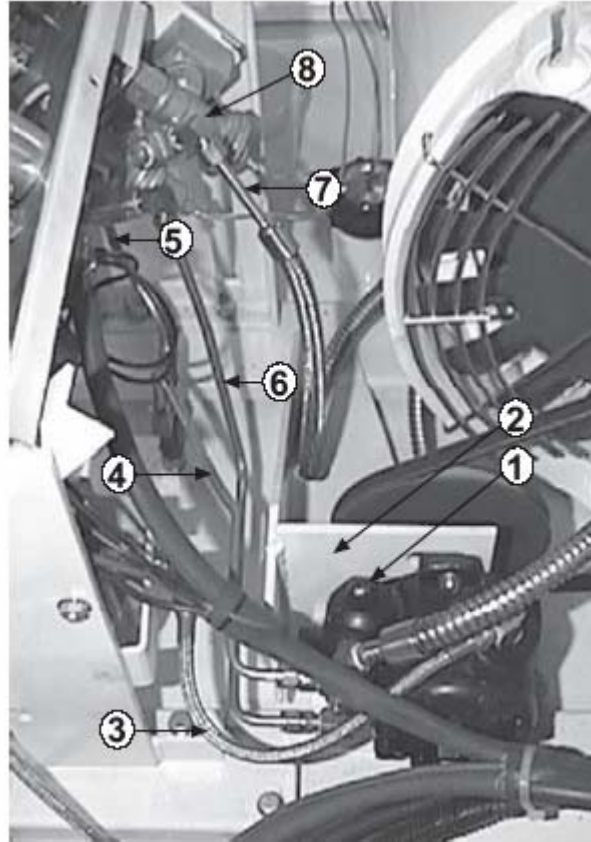

ITEM	DESCRIPTION
1	End Cap
2	Fuel Pump Mounting Bracket
3	Fuel Suction Line
4	Fuel Primary Return Line
5	Fuel Return Line
6	Burner Control Fuel Line
7	Fuel By-Pass Line
8	Temperature Control Valve



Section 5



5.27 Heat Exchanger Assembly Installation

5.28 To install heat exchanger assembly, proceed as follows:

- (a) Place heat exchanger on trailer assembly and align with engine. Using shims under heat exchanger mounting brackets may be required to obtain proper alignment. Maximum parallel misalignment is 0.015 inches. Maximum angular misalignment is 0.056 inches.
- (b) Tighten the 4 mounting bolts.
- (c) Install sensing element in discharge air stream and install duct adapter.
- (d) Install v-belt. Ensure proper belt tension.
- (e) Install capillary tube cover. Lift hood heater and install the 8 bolts.

5.29 Fan and Mounting Ring Assembly

5.30 The fan supplies all the air necessary for the operation of the heater. Power for the fan is transmitted by a flexible rubber bushing which mate with the drive coupling on the engine and a driven coupling which is pressed onto the fan shaft. A cast steel mounting ring supports the fan and associated parts.

5.31 Fan and Mounting Ring Removal

5.32 To remove fan and mounting ring assembly, proceed as follows:

- (a) Remove heat exchanger assembly following procedures listed in paragraph 5.25.
- (b) Remove the 3 bolts securing mounting ring to casing and remove ring.

5.33 Fan and Mounting Ring Installation

5.34 To install the fan and mounting ring assembly, reverse the removal procedures.

5.35 Heat Exchanger

5.36 Heat Exchanger Disassemble

5.37 To remove the heat exchanger, proceed as follows:

- (a) Remove heat exchanger assembly following procedures listed in paragraph 5.25.
- (b) Remove fan and mounting ring assembly following procedures listed in paragraph 5.31.
- (c) Disengage clamp from notches in combustion chamber. Remove nozzle holder and combustor plate.
- (d) Remove fuel lines from nozzle holder..
- (e) Remove ignition cable from igniter plug.
- (f) Remove exhaust stack and cover by removing the 12 screws and washers. Remove gasket.
- (g) Remove heat exchanger from heat exchanger housing by pulling the heat exchanger from the front of housing.



Section 5



5.38 Heat Exchanger Reassemble

5.39 To assemble the heat exchanger, reverse the disassemble procedures.

5.40 Carbon Monoxide Test

5.41 To check the heaters' ventilating air stream for carbon monoxide contamination, proceed as follows:

NOTE

On units that are used on a seasonal basis, this test shall be performed prior to the unit being put into service. A second test will be required if the heating season is longer than six month. Additional tests shall be performed any time contamination is suspected or if maintenance has been performed on exhaust system.

- (a) Attach one twelve inch duct to heater. Attach a duct adapter to the twelve inch duct and attach three six inch duct to adapter, *see figure 4-7*. Ensure there is no kinks in ducts.
- (b) Start heater using proper start procedures (paragraph 4.29). Rotate temperature selector valve to obtain a discharge temperature of 250°F.
- (c) Using a carbon monoxide tester, measure the carbon monoxide level at one of the six inch ducts. The carbon monoxide level will not exceed 35 PPM.

5.42 Heater Ignition System

5.43 Components of the ignition system are the coil, ignition cable and the igniter plug.

5.44 Coil

5.45 The coil is mounted on a bracket installed opposite the fuel pump.

5.46 Ignition cable and igniter plug

5.47 Ignition cable and plug removal

5.48 To remove ignition cable and igniter plug, proceed as follows:

- (a) Remove fan mounting ring by following the procedures listed in *Par. 5.31*.
- (b) Disconnect the ignition cable from igniter plug and coil.
- (c) Remove grommet from casing and remove ignition cable.
- (d) Remove igniter plug from combustion plate.
- (e) Disengage clamp from notches in combustion chamber and remove combustion plate (*see figure 5-3*).
- (f) Clean igniter plug and ignition cable and inspect for cracks, burning, pitting or other damage. Replace as necessary.



Figure 5-2 • Nozzle and Combustor (exploded view)

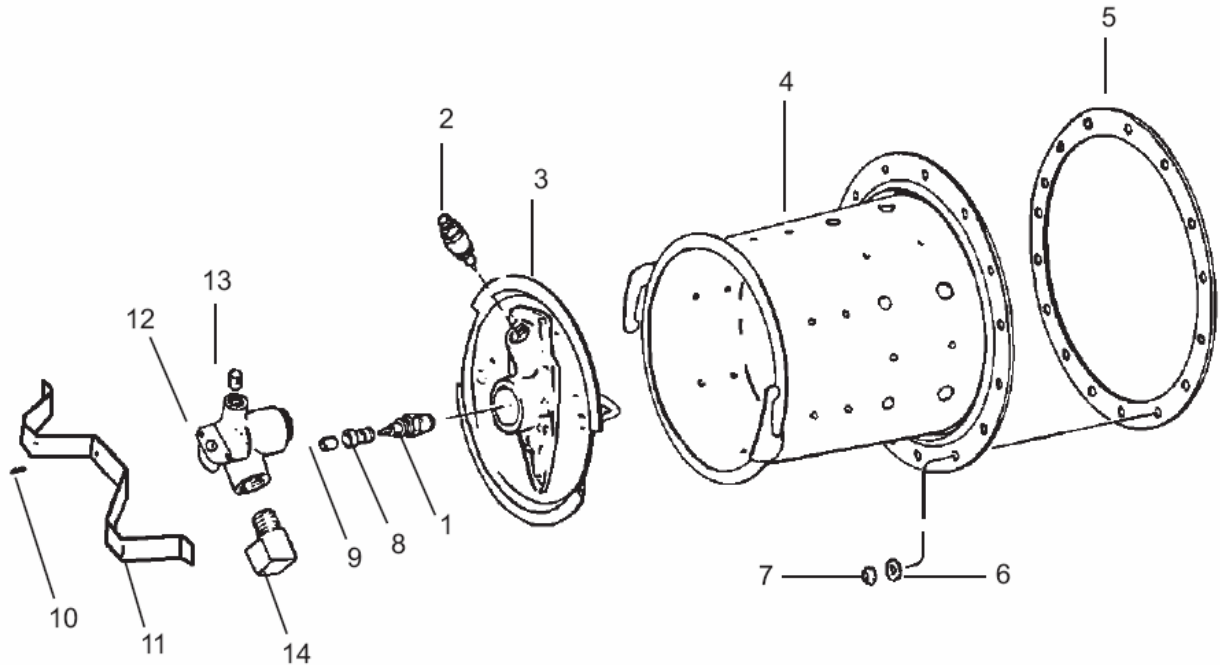

1	Nozzle (includes seal and strainer)	8	Strainer
2	Igniter plug	9	Seal
3	Combustor plate	10	Screw, machine (2)
4	Combustor assembly	11	Combustor clamp
5	Gasket	12	Nozzle holder
6	Washer, lock, 1/4 inch (16)	13	Pipe plug
7	Nut, self-locking, hex, stainless, 1/4-28 (16)	14	Elbow pipe



Section 5



5.49 Ignition Cable and Igniter Plug Installation

5.50 To install ignition cable and igniter plug, proceed as follows:

- (a) Install the igniter plug in the combustion plate. Measure the point gap. The gap should be 0.125 inch to 0.1875 inch (1/8 to 3/16). Bend the electrode to obtain correct gap (*see figure 5-3*).

!CAUTION!

Do not bend the igniter plug electrode

- (b) Install combustion plate on combustion chamber.
- (c) Insert nozzle holder, with clamp in notches on combustion chamber.
- (d) Insert ignition cable to igniter plug and magneto.
- (e) To install fan and mounting ring, follow procedures listed in *paragraph 5.33*.

5.51 Fuel Pump

5.52 The fuel pump is mounted on a bracket installed opposite the coil. The pump is belt driven by the engine.

Figure 5-3 • Igniter Plug Adjustment Points

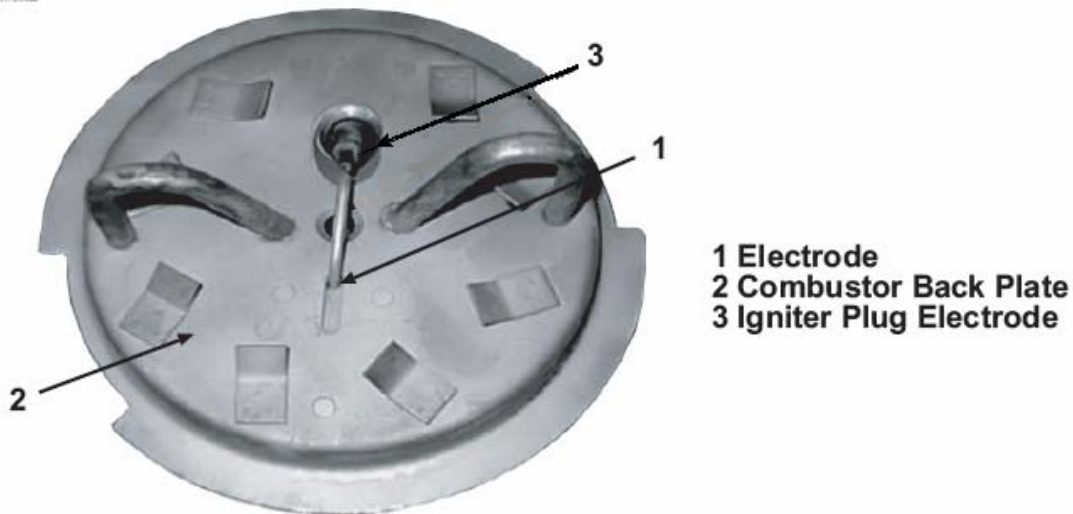



Section 5



5.53 Fuel Pump Adjustment

- 5.54 Pressure testing and adjustment of the fuel pump should be performed as follows:
- Gain access to the burner control valve by removing hood.
 - Remove plug from tee fitting at burner control valve (see figure 5-4). Install a 0-300 psi pressure gauge and needle valve (see figure 5-5). Ensure needle valve is closed.
 - Start engine and allow to warm up. During warm up, observe pressure gauge. The reading should be below 20 psi. Engage burner and ensure fuel has ignited. Pressure gauge should read 150 psi +/- 2 psi.
 - If pressure is not within tolerance, adjust pump by removing the end cap nut on top of pump and turning adjusting screw. Rotate screw clockwise to increase and counterclockwise to decrease pressure (see figure 5-7).

Figure 5-4 • Valve & Block Assembly

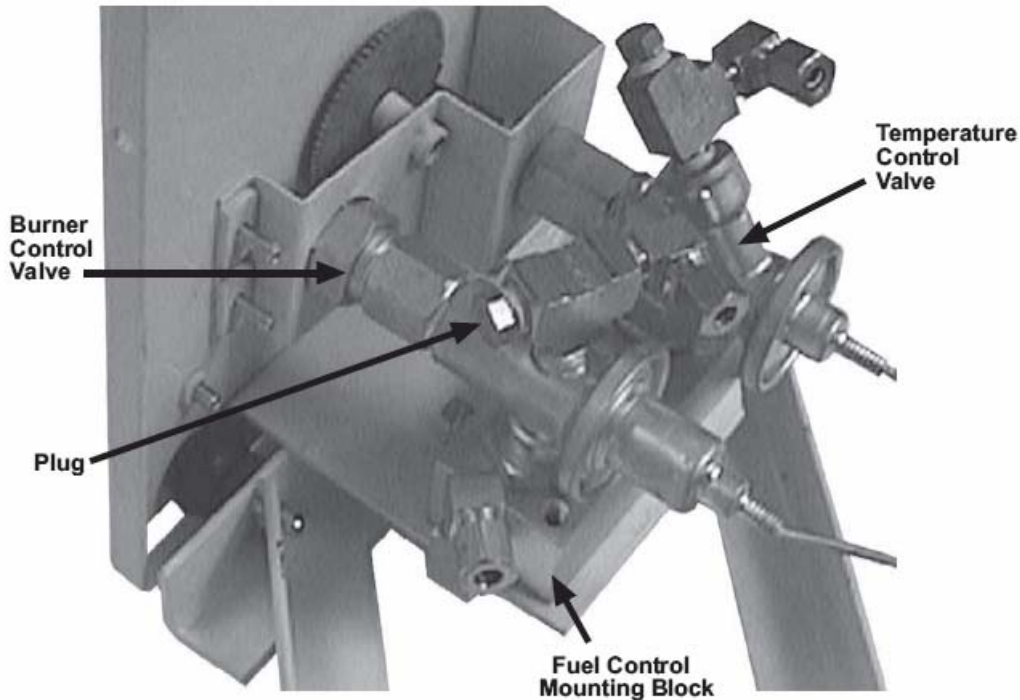
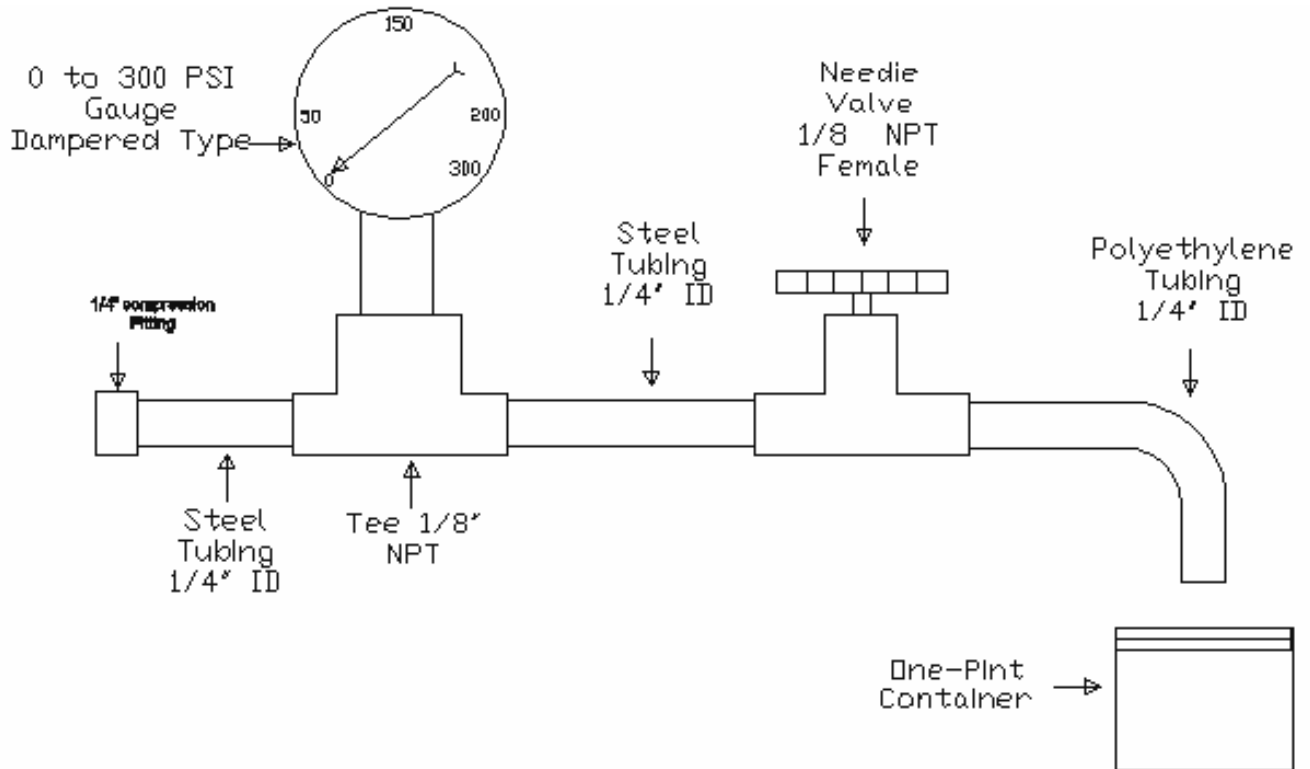



Figure 5-5 • Pump Pressure Testing Assembly





Section 5



5.56 Fuel Pump Flow Test

5.57 To check if the fuel pump has adequate fuel flow, proceed as follows:

- (a) Install pressure gauge with needle valve as in *paragraph 5.54*. Ensure needle valve is closed.
- (b) Start heater following proper start procedures.
- (c) Set heater to 250° and allow to stabilize (approx. 5 minutes). Ensure damper is in the fully open position.
- (d) With fuel pressure at 150 (+/- 2) psi, open needle valve slowly until pressure drops to 140 psi. Catch bleed-off fuel in a container with one pint marked. The burner should stay on and operate normally. Observe the time it takes to fill one pint while maintaining the fuel pressure at 140 psi. If the time taken is less than 2 minutes, the pump has adequate flow. If the time is more than 2 minutes, replace pump.
- (e) If pressure drops quickly when opening valve or burner shuts off, check for air leaks on pump inlet side (see paragraph 5.58).

5.58 Fuel Pump Air Leak Test

5.59 To check for air leaks, proceed as follows:

NOTE

Since the fuel flow on purge is about twice the fuel flow of a pressurized pump, test for air leak with the heater combustor not fired

- (a) Remove plug on fuel control mounting block and install toggle valve (*see figure 5-6*).
- (b) Start engine following proper start procedures. Do not engage burner control valve.

NOTE

Limit the time toggle valve is open to 30 seconds or less as fuel supply to engine is removed when toggle valve is open

- (c) Open toggle valve and allow a 2 inch depth of fuel to collect in container. Submerge end of tubing below the surface of the fuel. If air leaks exist in supply hose, connections or fuel pump air bubbles will be visible in container. Repair any leaks found.



Figure 5-6 • Fuel System Air Leak Testing Assembly

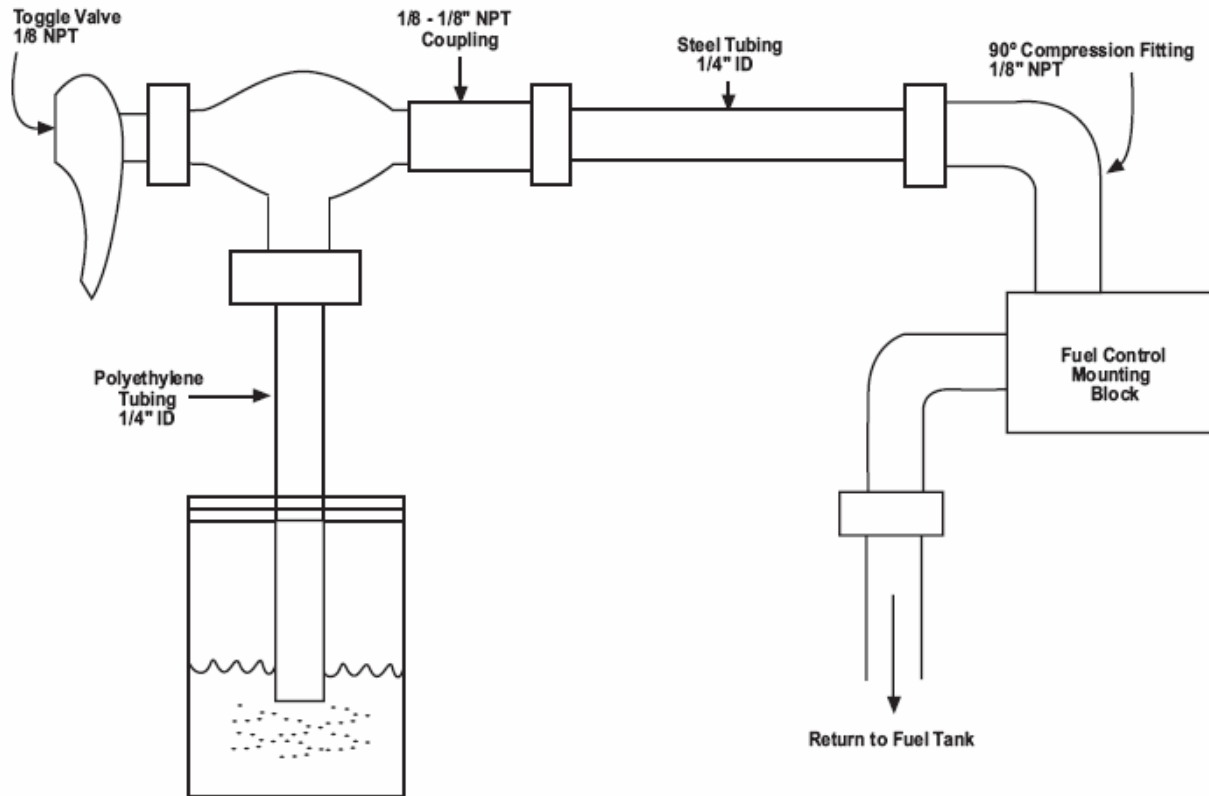



Section 5



5.60 Fuel Pump Removal

5.61 To remove the fuel pump, proceed as follows:

- (a) Remove the v-belt by slipping it off the fuel pump pulley (*see figure 5-1*).
- (b) Remove the fuel lines on the pump.
- (c) Remove the pulley by loosening the set screw.
- (d) Remove the mounting two bolts from the fuel pump and remove the pump.

5.62 Fuel Pump Installation

5.63 To install the fuel pump, reverse the removal procedures.

NOTE

**Check belt tension after installing the fuel pump.
Adjust following procedures listed in *paragraph 5.22*.**

5.64 Fuel Pump Strainer

5.65 Cleaning

5.66 To clean the fuel pump strainer, proceed as follows:

- (a) Remove the fuel pump from its mounting bracket. Follow procedures listed in *paragraph 5.60*.
- (b) Unscrew and remove the eight screws attaching cover to pump body. Remove cover and gasket from pump body.
- (c) Remove strainer from body. Wash strainer using an approved cleaning solvent. Allow strainer to air dry.
- (d) Clean out any dirt remaining in body.

NOTE

**If there is evidence of rust inside pump body,
check fuel filter and fuel tank for water contamination.**



Section 5 • Troubleshooting



5.67 Troubleshooting

5.68 A tabulation of troubleshooting is contained in *Table 5-3*. The table lists probable causes of and probable remedies for correcting the malfunctions of the heater. The malfunctions and possible causes are listed in the order in which they are most apt to occur. The troubleshooting procedures assume all operating controls are properly set adjusted for the selected mode of operation.

Table 5-3 • Troubleshooting Chart



	TROUBLE	PROBABLE CAUSE	REMEDY
1	Engine will not turn over	1. Battery cables loose or not connected	Connect battery cables or tighten
		2. Exhausted battery.	Replace with serviceable battery.
		3. Defective starter.	Replace starter.
2	Engine turns over but fails to start or starts then stops	1. Cold weather below 5°F (-15° C).	Refer to paragraph 4.34.
		2. Insufficient fuel supply.	Fill tank with appropriate fuel.
		3. Clogged filter.	Replace filter.
		4. Fuel return check valve dirty.	Clean or replace check valve.
		5. Faulty fuel pump.	Check fuel pump paragraph 5.56.
		6. V-belt slipping	Adjust v-belt.
		7. Engine fault	Refer to engine supplement
3	Engine stops suddenly	1. Fuel tank empty.	Fill fuel tank with appropriate fuel
		2. Contaminated fuel.	Drain and flush tank.
		3. Incorrect fuel supply.	Drain and flush tank.
4	Burner fails to ignite	1. Insufficient fuel supply.	Refer to trouble 2 probable causes 2 and 3
		2. Defective fuel pump.	Check fuel pump paragraph causes 2 and 3
		3. Fuel pump pulley slipping.	Tighten set screen on pulley.
		4. Defective burner control valve.	Replace burner control valve.
		5. Defective coil.	Replace with serviceable coil.
		6. Defective ignition cable.	Replace cable paragraph 5.46.
		7. Defective igniter plug.	Adjust igniter paragraph 5.50 or replace.
		8. Fuel nozzle dirty or defective.	Clean nozzle or replace.
5	Burner ignites by itself	1. Defective burner control valve.	Replace burner control valve



Section 5 • Troubleshooting Cont'd



	TROUBLE	PROBABLE CAUSE	REMEDY
6	Excessive smoke emitted from exhaust	1. Air flow restricted	Remove restriction.
		2. Diesel engine operating below normal speed.	Check engine speed. If incorrect adjust to 3600 rpm (refer to engine supplement).
		3. Incorrect nozzle spray pattern.	Clean or replace nozzle.
		4. Carbon buildup in exhaust system.	Clean exhaust system.
		5. Excessive fuel pressure.	Adjust pump pressure (see paragraph 5.53).
7	Combustor flame cuts out	1. Insufficient air supply.	Refer to trouble 2 probable causes 2 and 3.
		2. Discharge air restricted.	Remove restriction.
		3. Burner control valve sensor element improperly positioned in air stream.	
		4. Defective burner control valve.	Replace valve.
		5. Defective temperature selector valve.	Replace valve.
		6. Clogged nozzle.	Clean or replace.
8	Combustor flame fails to go out or unit overheats	1. Defective burner control valve.	Replace valve.
		2. Defective temperature selector valve.	Replace valve.
9	Maximum heat output not obtainable	1. Fuel system leak.	Inspect fuel lines, tighten loose connections. Replace damaged fuel lines.
		2. Defective fuel pump.	Check pump (paragraph 5.53 to 5.59).
		3. Clogged fuel filter.	Inspect and replace filter.
		4. Defective temperature selector valve.	Replace valve.
		5. Heat exchanger clogged.	Clean heat exchanger.
10	After burning in combustion chamber	1. Nozzle check valve being held open by contaminant.	Clean or replace valve.
		2. Defective nozzle.	Clean or replace nozzle.
		3. Fuel leak in nozzle holder or fuel line at nozzle holder.	Tighten or replace fuel lines.



Section 6 • Parts List

Figure 6-1 • Ducts & Accessories

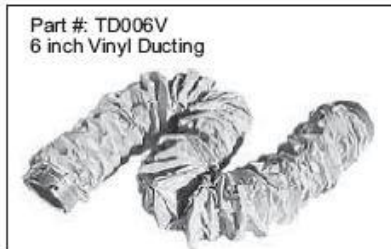
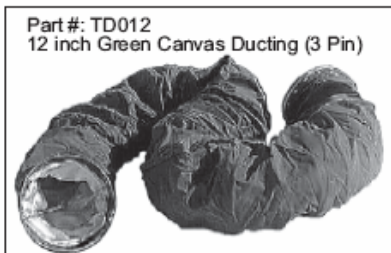
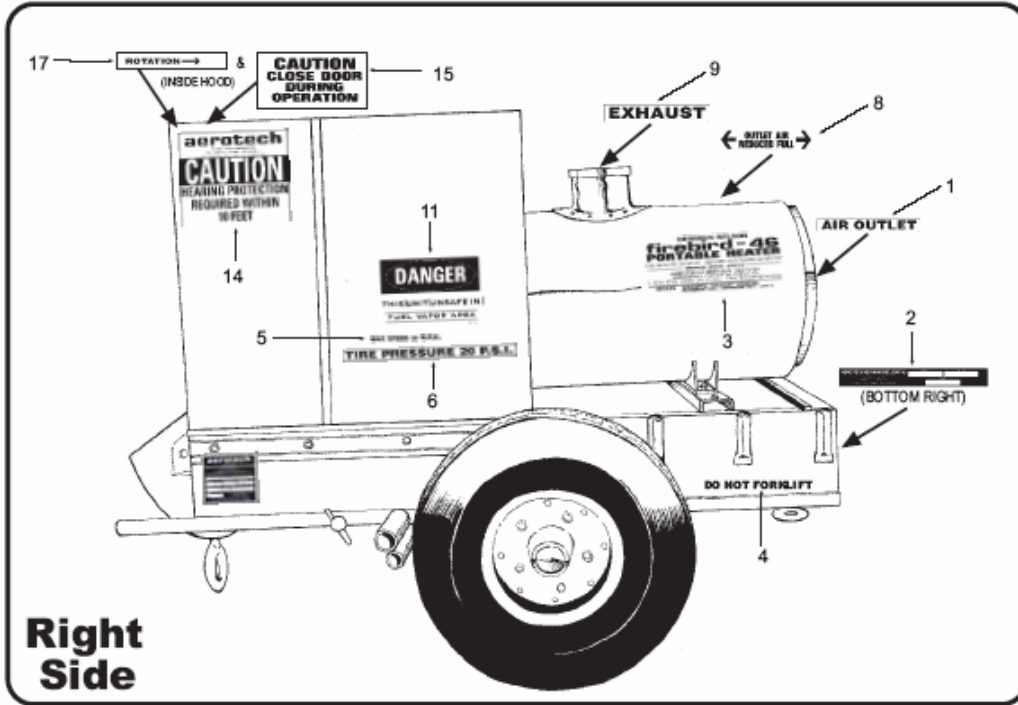
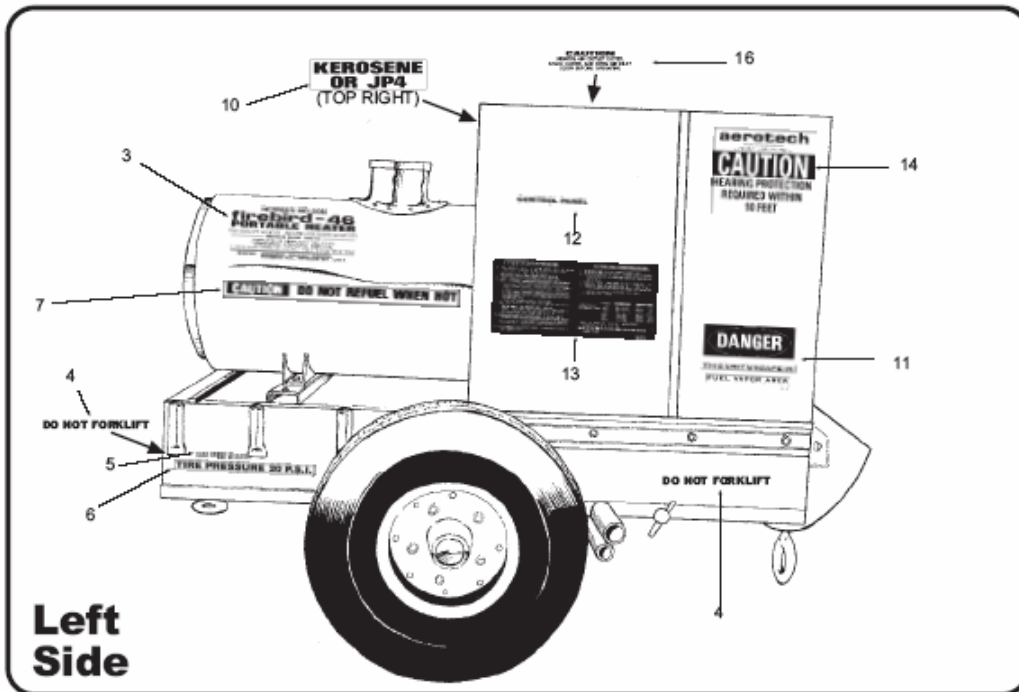



Figure 6-2 • 400-46 Decal Configuration



Right Side



Left Side



Figure 6-2 • Decals Parts List



Fig. & Index #	Part #	Description	Units per Ref.
6-2		Heater Assembly	
1	04010207	• DECAL "AIR OUTLET"	1
2	05000134	• PLATE, TRAILER "I.D."	1
3	05000128	• DECAL "FIREBIRD-46"	2
4	04110199	• DECAL "DO NOT FORKLIFT"	3
5	04010211	• DECAL "MAX SPEED 20 MPH"	2
6	04010212	• DECAL "TIRE PRESSURE 20 PSI"	2
7	05000127	• DECAL "DO NOT REFUEL WHEN HOT"	1
8	05000126	• DECAL "OUTLET AIR" REDUCED FULL	1
9	05000129	• DECAL "EXHAUST"	1
10	05000125	• DECAL "KEROSENE OR JP4"	1
11	04010152	• DECAL "DANGER, THIS UNIT UNSAFE IN FUEL VAPOR AREA"	2
12	05000142	• DECAL "CONTROL PANEL"	1
13	04110229	• INFORMATION PLATE "STARTING PROCEDURES"	1
14	05000130	• DECAL "CAUTION, HEARING PROTECTION"	2
15	04010120	• DECAL "CAUTION, CLOSE DOOR DURING OPERATION"	1
16	04010209	• DECAL "CAUTION, REMOVE AIR OUTLET"	1
17	04010205	• DECAL "ROTATION"	1



Figure 6-3 • Hood Assembly

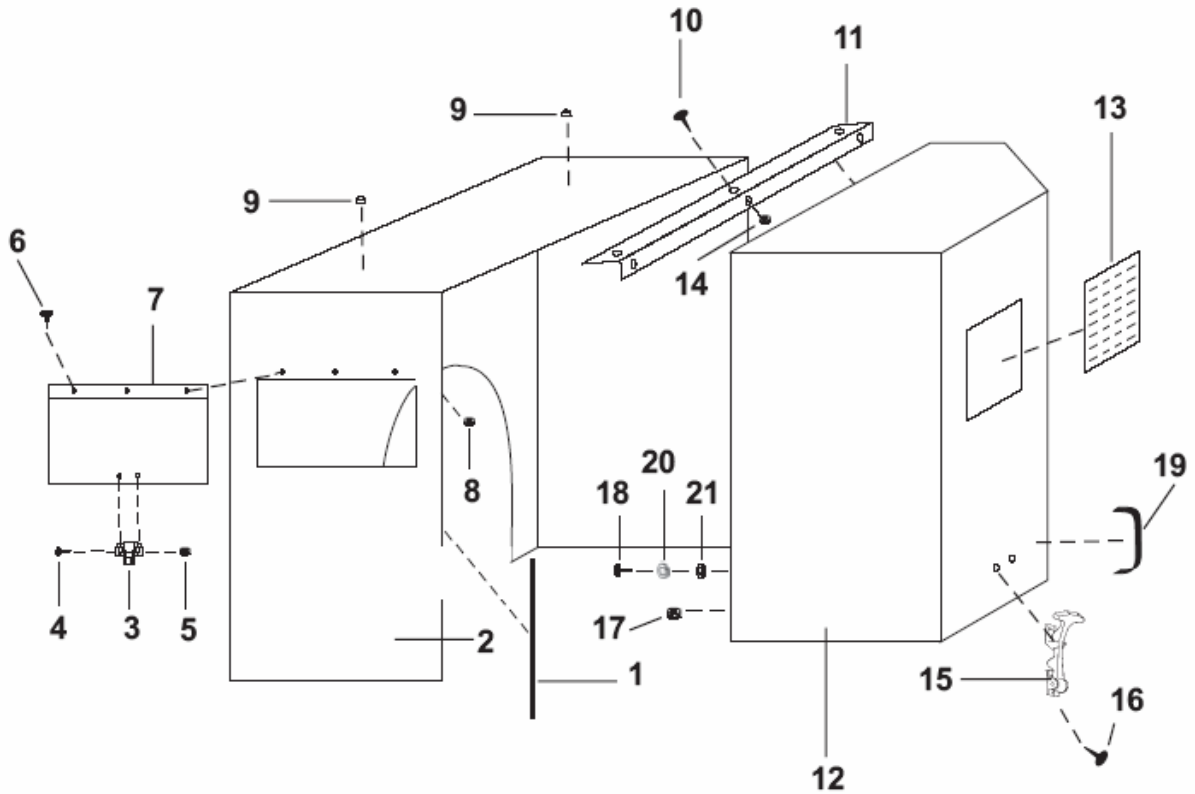



Figure 6-3 • Hood Assembly



Fig. & Index #	Part #	Description	Units per Ref.
6-3		Hood Assembly	
1	05000140	• WEATHER STRIPS, HOOD	4
2	05000121	• HOOD, REAR	1
3	04010061	• LATCH, ACCESS DOOR	1
4	SC632X34MS	• SCREW 6-32 x 3/4 in	2
5	NT632KEP	• NUT-KEP 6-32	2
6	SC1024X12MS	• SCREW 10-24 x 1/2 in.	3
7	04110224	• ACCESS DOOR, CONTROL PANEL	1
8	NT632KEP	• NUT-KEP 6-24	3
9	05000123	• HOOD REST, RUBBER	2
10	SC1024X34MS	• SCREW 10-24 x 3/4 in.	5
11	05000141	• HINGE, HOOD	1
12	05000120	• HOOD, FORWARD	1
13	05000124	• LOOVERED ALUMINUM PLATE	2
14	NT1024KEP	• NUT-KEP 10-24	5
15	05000122	• LATCH, HOLD DOWN	2
16	SC1024X12MS	• SCREW 10-24 x 1/2 in.	4
17	NT1024KEP	• NUT-KEP 10-24	4
18	SC1024X12MS	• SCREW 10-24 x 1/2 in.	2
19	05000139	• HANDLE, HOOD	1
20	WSSR10	• WASHER LOCK #10	2
21	WSFT10	• WASHER #10	2



Figure 6-4 • Heater Assembly

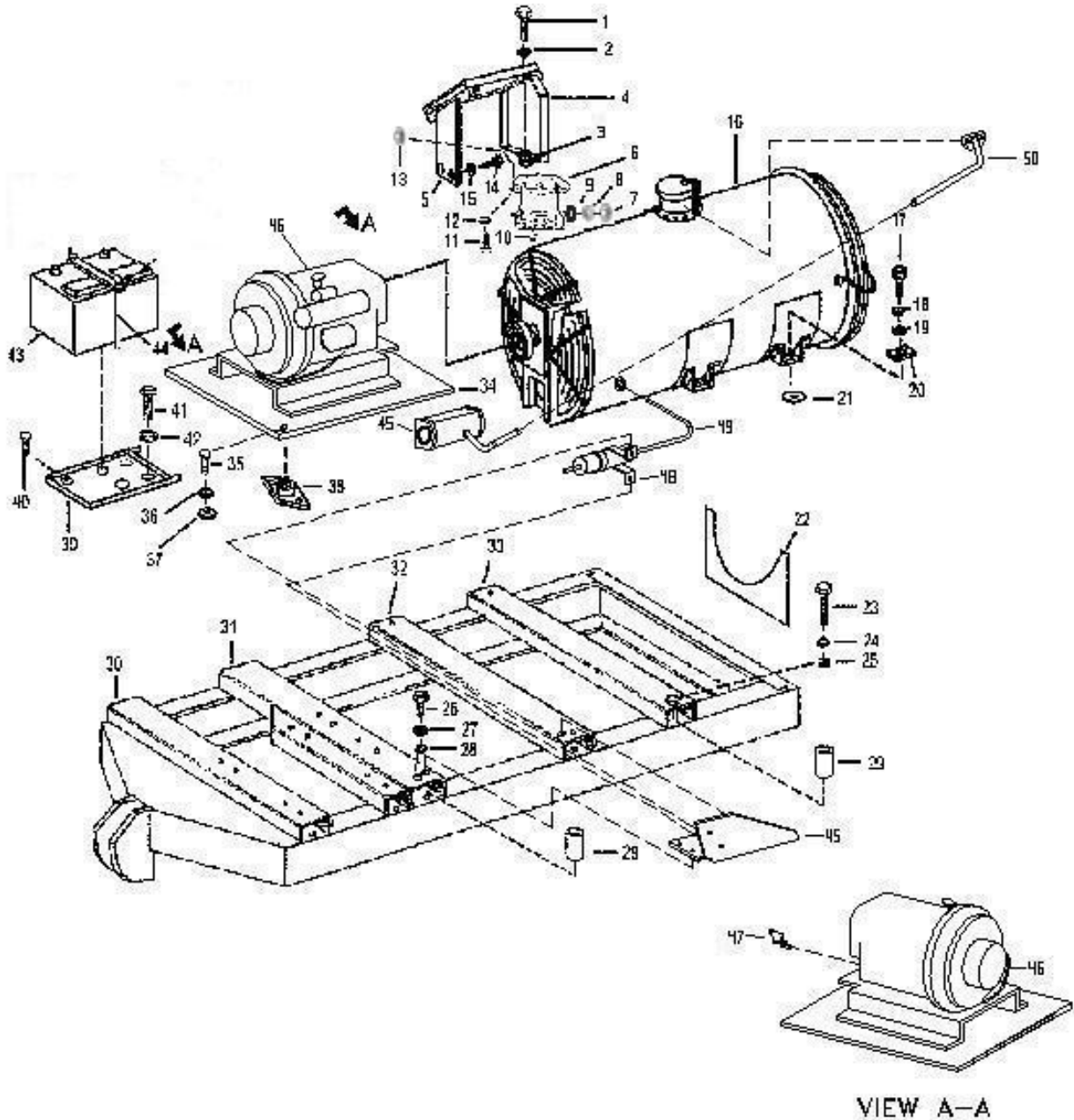



Figure 6-4 • Heater Assembly



Fig. & Index #	Part #	Description	Units per Ref.
6-4		Heater Assembly	Ref.
1	BL14X134	• BOLT 1/4-20 x 1 3/4 in.	4
2	WSFT14	• WASHER, FLAT 1/4 in.	4
3	04100179	• MOUNT, RESILIENT, PANEL	4
4	05000119	• PANEL SUPPORT (REAR)	1
5	05000118	• PANEL SUPPORT (FORWARD)	1
6	04100139	• SOLENOID, PREHEAT	1
7	NT516NLN	• NUT 5/16-20	2
8	WSSR516	• WASHER, LOCK 5/16 in.	2
9	WSFT516	• WASHER, FLAT 5/16 in.	2
10	NT1032KEP	• LOCKNUT 10-32.	2
11	BL14X34	• BOLT 1/4-20 x 3/4 in.	2
12	WSFT14	• WASHER, FLAT 1/4	2
13	NT1420KEP	• NUT-KEP 1/4-20	2
14	BL516X34	• BOLT 5/16-18 x 3/4 in.	4
15	WSSR516	• WASHER, LOCK 5/16 in.	4
16	no number	• HEAT EXCHANGER ASSY (SEE FIG. 6.14 FOR DETAILED BREAKDOWN)	1
17	BL516X34	• BOLT 5/16-18 x 3/4 in.	4
18	WSSR516	• WASHER, LOCK 5/16 in.	4
19	WSFT516	• WASHER, FLAT 5/16 in.	4
20	TA218A	• WASHER	4
21	WSFT12	• WASHER, FLAT 1/2 in.	as required
22	05000114	• LOWER BULKHEAD	1
23	BL14X134	• BOLT 1/4-20 x 1 3/4 in.	4
24	WSSR14	• WASHER, LOCK 1/4 -20 x 2 in.	4



Figure 6-4 • Heater Assembly



Fig. & Index #	Part #	Description	Units per
6-4		Heater Assembly	Ref.
25	WSFT14	• WASHER, FLAT 1/4 in.	4
26	BL516X112	• BOLT, FLANGE, 5/16 x 1 1/2	4
27	WSSR14	• WASHER, LOCK 1/4 in.	4
28	WSFT14	• WASHER, FLAT 1/4 in.	4
29	04130024-2	• SPACER	8
30	05000135	• ENGINE SUPPORT (FORWARD)	1
31	05000136	• ENGINE SUPPORT (REAR)	1
32	05000137	• HEAT EXCHANGER SUPPORT (FORWARD)	1
33	05000138	• HEAT EXCHANGER SUPPORT (REAR)	1
34	05000145	• PLATE, ENGINE MOUNT	1
35	BL516X134	• BOLT 5/16-18 x 1 3/4 in.	5
36	WSSR38	• WASHER, LOCK, SPLIT RING 3/8	5
37	WSFT38	• WASHER, FLAT 3/8 in.	5
38	05100141	• MOUNT, RESILIENT, ENGINE	5
39	05000117	• BATTERY TRAY	1
40	SC1420X34FH	• SCREW, FLATHEAD 1/4-20 x 3/4 in.	2
41	BL14X34	• BOLT 1/4-20 x 3/4 in.	2
42	WSFT14	• WASHER, FLAT 1/4 in.	2
43	13130	• BATTERY 12 VOLT	1
44	05000146	• BATTERY HOLD DOWN	1



Figure 6-4 • Heater Assembly



Fig. & Index #	Part #	Description	Units per Ref.
6-4		Heater Assembly	
45	20018-1	• COIL MOUNTING BRACKET	1
46	L48EEDEAH	• ENGINE	1
47	04100114	• OIL PRESSURE SWITCH	1
48	04100112	• IGNITER COIL	1
49	04100156	• IGNITER CABLE	1
50	TMF3240	• PIPE EXHAUST	1



Figure 6-5 • Diesel Engine

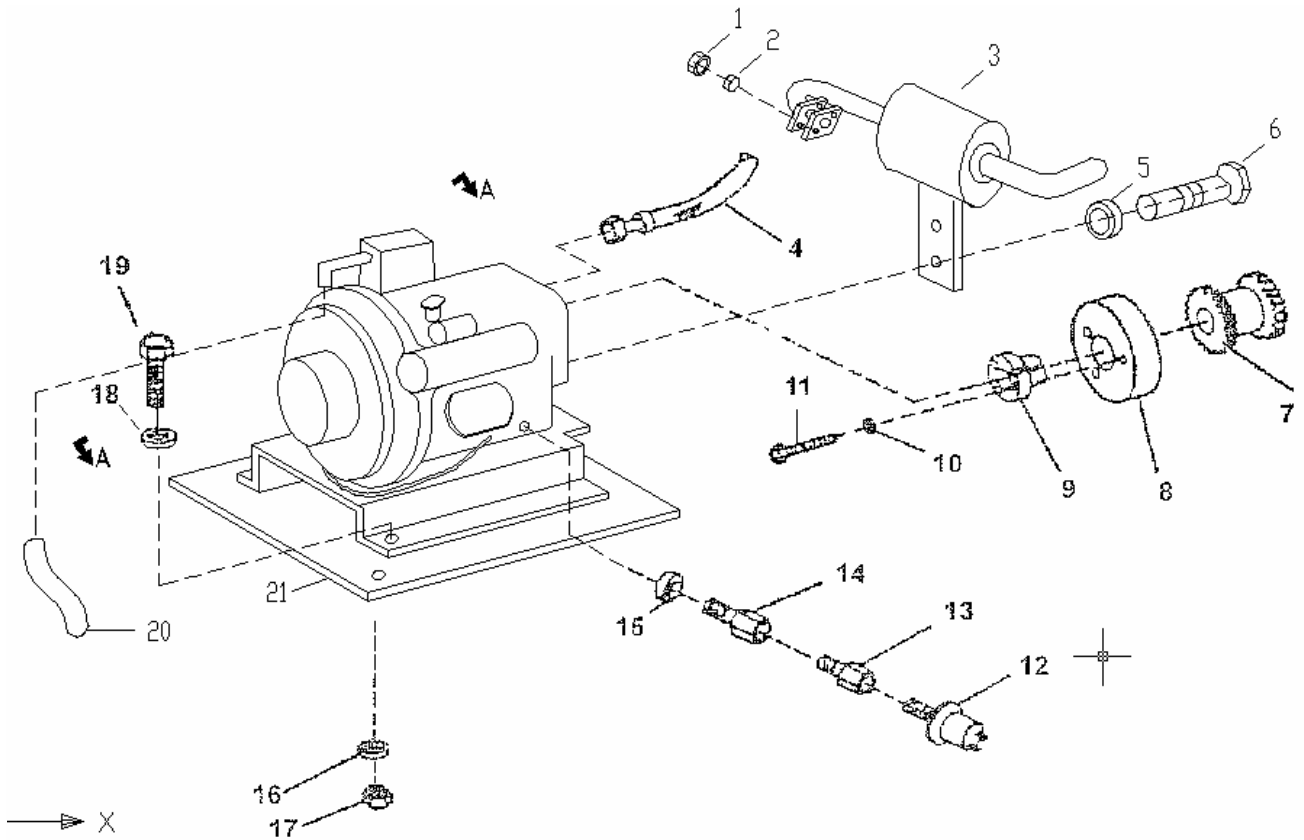



Figure 6-5 • Diesel Engine



Fig. & Index #	Part #	Description	Units per Ref.
6-5		Engine, Diesel (see supplement for details)	
1	common	• NUT 5/16-24	2
2	common	• WASHER, LOCK 5/16 in.	2
3	04100106	• MUFFLER – LISTER PETTER	1
	0510009-2	- YANMAR	1
	0510009-3	- KUBOTA	1
4	04100157-1	• FUEL LINE, ENGINE FLEX	1
5	common	• WASHER 5/16 in.	2
6	common	• BOLT 5/16-18 x 3/4 in.	2
7	TM3917-2	• SLEEVE, FLEX COUPLING	1
8	04100199	• DRIVE COUPLING - LISTER PETTER	1
	TM3917-3	- YANMAR	1
	04100199	- KUBOTA	1
9	04110198	• SLEEVE BUSHING	1
10	WSFT10	• WASHER #10	3
11	SC1024X1MS	• SCREW 10-24 x 1 in.	3
12	04100114	• SWITCH, OIL PRESSURE	1
13	BF7842	• ADAPTER	1
14	BF7874	• COUPLER	1
15	04100371	• GASKET	1
16	WS1NT38	• WASHER, LOCK 3/8 in.	4
17	NT38HN	• NUT 3/8-16 in.	4
18	WSFT38	• WASHER, FLAT 3/8 in.	4
19	BL38X112	• BOLT 3/8-16 x 1 1/2 in.	4
20	80057	• FUEL LINE, RETURN	1
21	0510011-1	• BASE PLATE, ENGINE MOUNT - LISTER PETTER	1
	0510011-2	- YANMAR	1
	0510011-3	- KUBOTA	1



Figure 6-6 • Fuel System

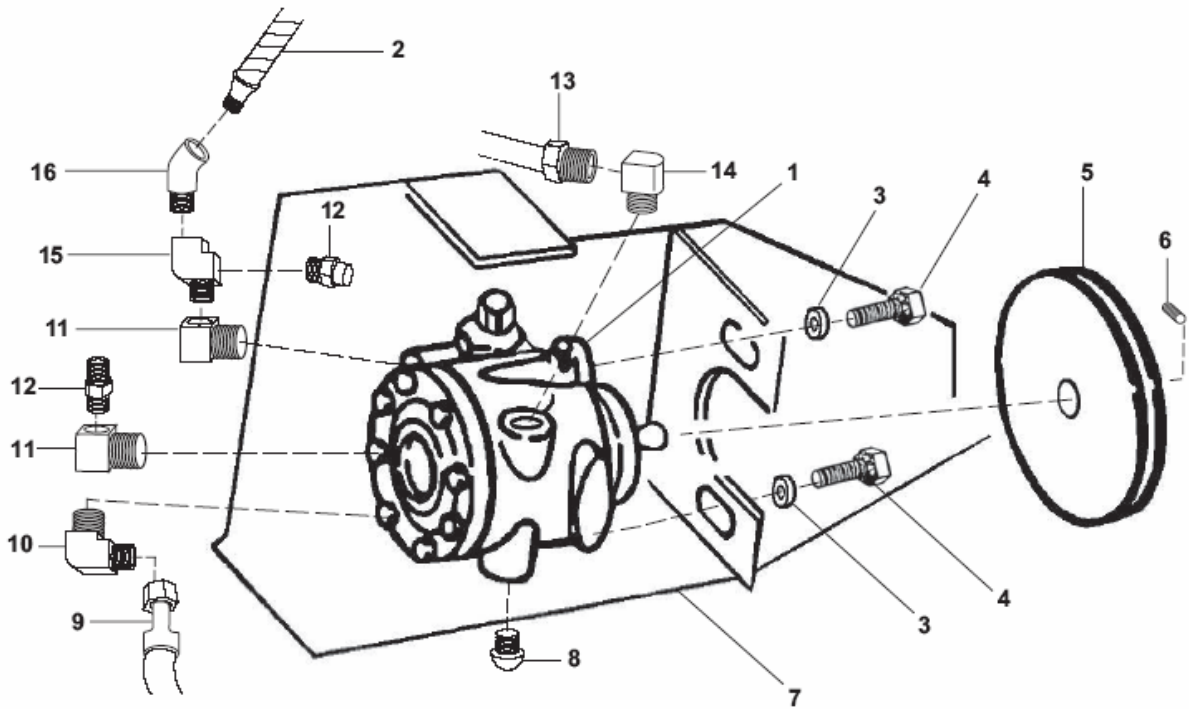



Figure 6-6 • Fuel System



Fig. & Index #	Part #	Description	Units per Ref.
6-6		Fuel System	
1	TR3277	• FUEL PUMP (see fig. 6-9 for detailed breakdown)	1
2	04100157-1	• FUEL LINE, ENGINE	1
3	WSFT12	• WASHER, FLAT 1/2 in.	2
4	BL12X114	• BOLT 1/2-13 x 1 1/4 in.	2
5	TM3919	• PULLEY	1
6	T0653A	• SET SCREW	1
7	05000148	• BRACKET, FUEL PUMP MOUNT	1
8	BF7823	• PLUG	1
9	04100157-1	• FUEL LINE, PRESSURE	1
10	BF7810	• 90° ELBOW, BRASS FITTING	1
11	BF7808	• 90° ELBOW	2
12	T0555A	• TUBE PIPE CONNECTOR	2
13	T0555A	• FUEL LINE, PICK UP	1
14	BF7809	• 90° ELBOW	1
15	BF7827	• STREET TEE	1
16	BF7814	• 45° ELBOW BRASS FITTING	1



Figure 6-7 • Fuel Pump

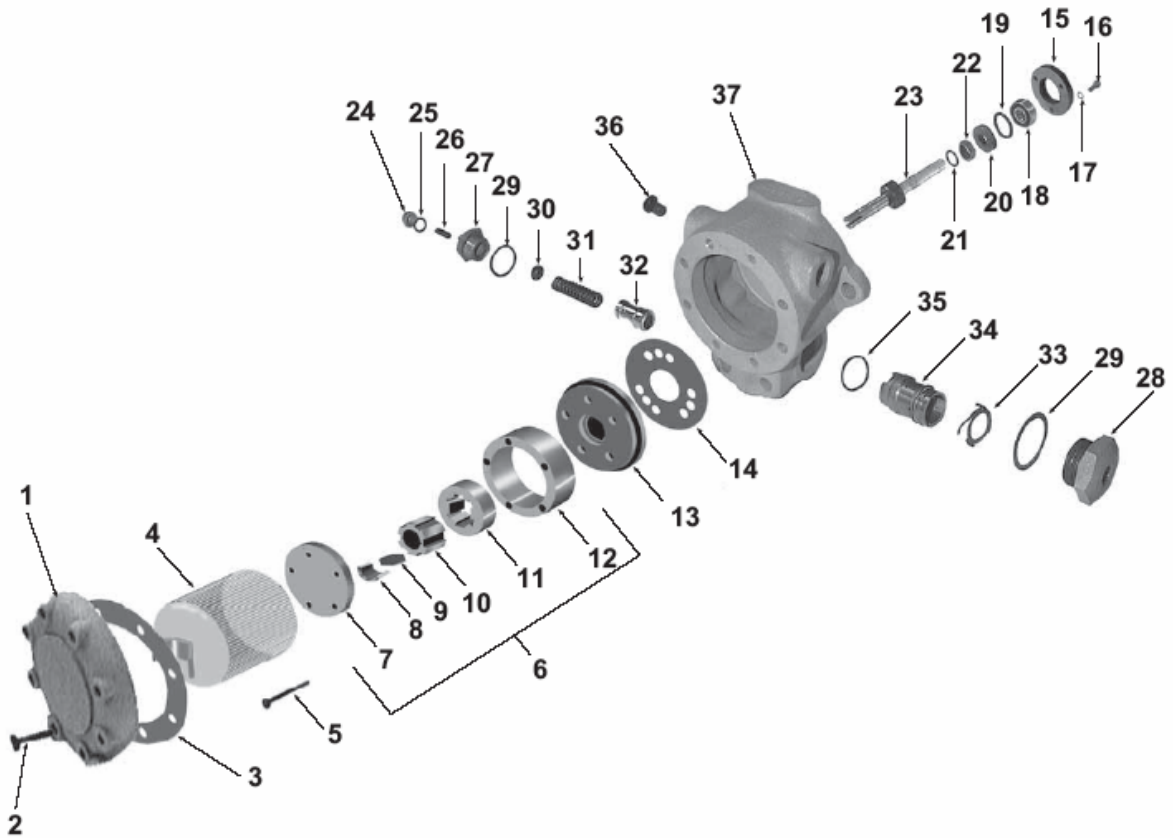



Figure 6-7 • Fuel Pump



Fig. & Index #	Part #	Description	Units per Ref.
6-7	TR3277	Fuel Pump	
1	117463	• COVER, PUMP (attaching parts)	1
2	111401	• BOLT, COVER	8
3	110441	• GASKET, COVER	1
4	111302	• STRAINER, FUEL PUMP	1
5	105021	• BOLT, END PLATE	1
6	127297	• PLATE, END includes items 7,8,9,10,11 and 12	1
7	127297	• PLATE, END	1
8	127297	• CRESCENT	1
9	1271131	• KEY, DRIVE	1
10	127297	• ROLLER	1
11	127297	• ROTOR	1
12	127297	• HOUSING, ROTOR	1
13	131201	• HOUSING, PORT	1
14	113331	• GASKET, PORT HOUSING	1
15	118732	• RETAINER, BEARING (attaching parts)	1
16	51295	• BOLT, RETAINER	3
17	WSSR06	• WASHER, LOCK #6	3
18	1615DC	• BEARING, BALL, ANNULAR	1
19	123632	• PACKING, SEAL O'RING	1



Figure 6-7 • Fuel Pump



Fig. & Index #	Part #	Description	Units per Ref.
6-7	TR3277	Fuel Pump	
20	115462	• FACE, SEAL	1
21	123652	• PACKING, PREFORMED SEAL	1
22	127562	• HOUSING, SEAL	1
23	131199	• SHAFT, PUMP	1
24	100241	• NUT, END CAP	1
25	100371	• GASKET, END CAP	1
26	101001	• SCREW, ADJUSTING	1
27	103379	• PLUG, END	1
28	114227	• PLUG, END	1
29	100901	• WASHER, NONMETALLIC GASKET, END PLUG	2
30	100931	• SEAT, SPRING	1
31	101641	• SPRING, HELICAL COMPRESSION	1
32	116106	• PISTON, FUEL PUMP	1
33	121732	• RETAINER, SPRING SLEEVE	1
34	121222	• SLEEVE, PISTON	1
35	28778	• PACKING, PREFORMED O'RING	1
36	BF7823	• PLUG, PIPE	1
37	131196	• BODY, PUMP	1



Figure 6-8 • Control Panel Assembly

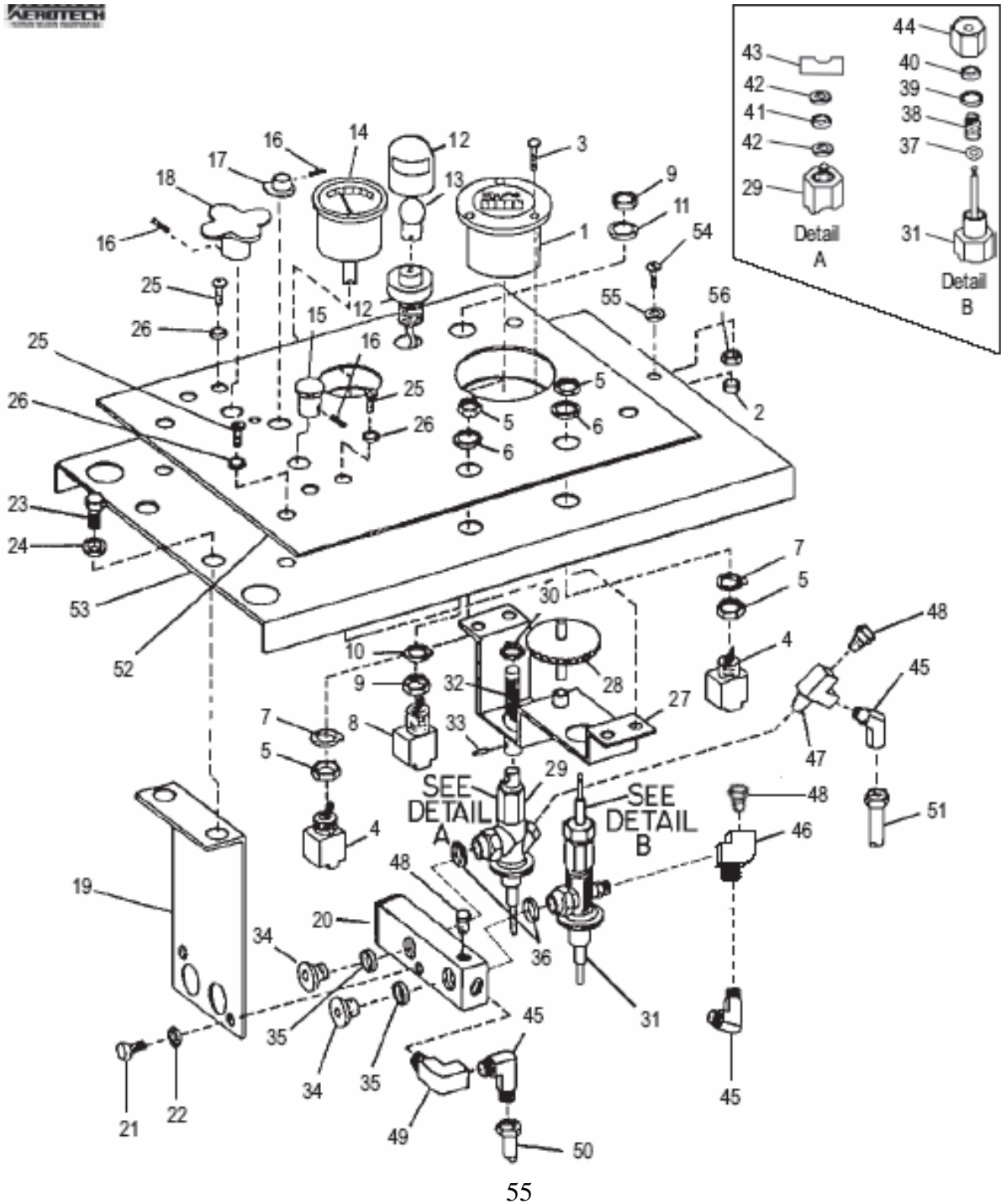

AEROTECH HERMAN NELSON INTERNATIONAL INC.
100 Eagle Drive, Winnipeg, Manitoba Canada R2R 1V5
Phone: 204-633-1999 (24 Hours) Fax: 204-694-1612 Email: Air4ce45@aol.com
Check Out Our Web site www.hermannelson.com New Items Added Weekly
12.18.07 REVISION 1.02



Figure 6-8 • Control Panel Assembly



Fig. & Index #	Part #	Description	Units per Ref.
6-8		Control Panel Assembly	
1	MIL-M-3971/1-1	• HOURMETER	1
2	common	• NUT 6-32 KEP	3
3	common	• SCREW 6-32 x 1/2 in.	3
4	MS24523-30	• SWITCH, TOGGLE, SPRING RETURN	2
5	no number	• LOCKNUT (part of item #4)	4
6	no number	• WASHER (part of item #4)	2
7	no number	• WASHER (part of item #4)	2
8	MS24523-22	• SWITCH, TOGGLE	1
9	no number	• LOCKNUT (part of item #8)	2
10	no number	• WASHER (part of item #8)	1
11	no number	• WASHER (part of item #8)	1
12	04100178	• PANEL LIGHT ASSEMBLY	1
13	TS623	• BULB, PANEL LIGHT	1
14	TR3276	• GAUGE, TEMPERATURE	1
15	T0587C	• KNOB, BURNER CONTROL VALVE	1
16	T0653A	• SET SCREW	3
17	T0586E	• KNOB TEMPERATURE INDICATOR	1
18	T0574C	• HANDLE, TEMPERATURE SELECTION VALVE	1
19	04100175	• SUPPORT, CONTROL BLOCK	1
20	TR3269	• BLOCK, FUEL CONTROL	1



Figure 6-8 • Control Panel Assembly



Fig. & Index #	Part #	Description	Units per Ref.
6-8		Control Panel Assembly	Ref.
21	common	• SCREW, BRACKET SUPPORT 1/4-20 x 1 in.	2
22	common	• WASHER, 1/4 in.	2
23	common	• BOLT 1/4-20 x 1/2 in.	2
24	common	• WASHER, FLAT #10	2
25	common	• SCREW 10-24 x 3/4 in.	8
26	common	• WASHER, FLAT	8
27	04100172	• BRACKET, FUEL CONTROL	1
28	T0F64C	• GEAR, TEMPERATURE SELECTOR	1
29	TR3274	• VALVE, TEMPERATURE SELECTOR	1
30	T0539A	• NUT, LOCKING	1
31	TR3275	• VALVE, BURNER CONTROL	1
32	T0540A	• STEM, TEMPERATURE SELECTOR VALVE	1
33	MS171591	• ROLL, PIN	1
34	T0542	• BOLT, FLUID PASSAGE	2
35	MS29513-112	• PACKING, PREFORMED O'RING	2
36	MS29513-016	• PACKING, PREFORMED O'RING	2
37	EVL-22772	• WASHER, COPPER	1
38	EVL-18080	• SPRING, PACKING	1
39	EVL-13483	• PACKING EXPANDER	1
40	EVL-14260	• PACKING, PREFORMED	1



Figure 6-8 • Control Panel Assembly



Fig. & Index #	Part #	Description	Units per Ref.
6-8		Control Panel Assembly	
41	EVL-54165	• PACKING, PREFORMED	1
42	EVL-42310	• WASHER, BRASS	2
43	EVL-63224	• PACKING SCREW	1
44	EVL-13984	• PACKING NUT	1
45	BF-7810	• 90° TUBE ELBOW	3
46	BF-7817	• STREET TEE	1
47	BF-7827	• PIPE TEE	1
48	BF-7819	• PLUG	3
49	TR3275	• 90° ELBOW	1
50	T0539A	• FUEL RETURN LINE	1
51	04100157-1	• FUEL, BYPASS LINE	1
52	04130013	• NAME PLATE, CONTROL PANEL	1
53	MS171591	• CONTROL PANEL	1
54	04010104	• SCREW 10-24 x 3/4 in.	1
55	WSFT10	• WASHER FLAT #10	1
56	MS29513-116	• NUT 10-24 KEP	1



Figure 6-9 • Fuel Filter

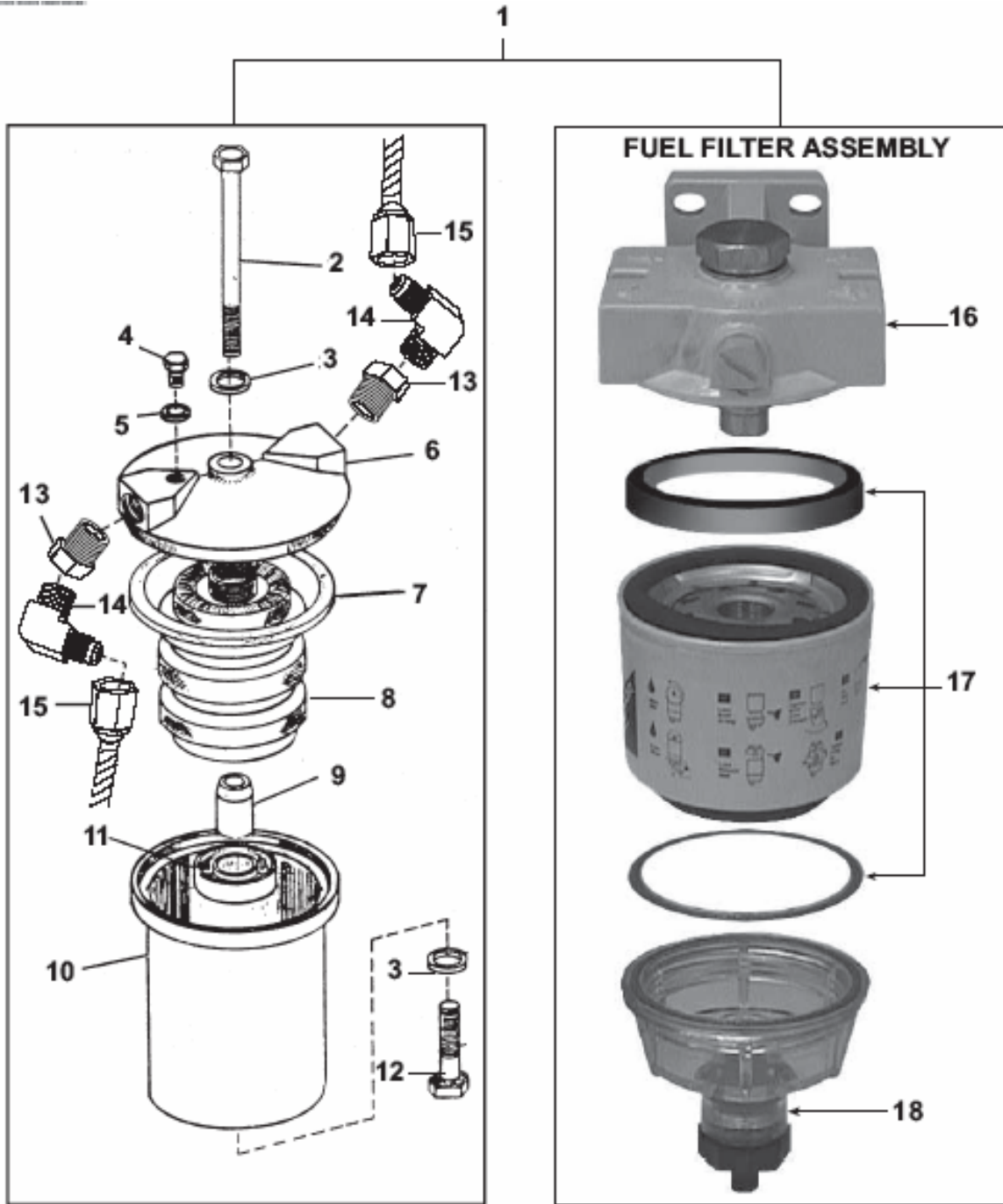



Figure 6-9 • Fuel Filter



Fig. & Index #	Part #	Description	Units per Ref.
6-9		Fuel Filter	
1	1A-25A	• FUEL FILTER, 04130140 (complete assy)	1
	120R	• FUEL FILTER, (RACOR) (complete assy)	1
2	1A-33	• BOLT, CENTER	1
3	1A-58	• GASKET	2
4	1A-38	• SCREW, VENT	1
5	1A-39	• GASKET, AIR BLEED	1
6	1A-26A	• CAP, FILTER	1
7	1A-31A	• GASKET, HEAD	1
8	1A-30	• ELEMENT ASSEMBLY C/W GASKET	1
9	1A-28A	• SPUD, CENTER	1
10	1A-27B	• BODY, FILTER	1
11	1A-37	• CUP, SEALING	1
12	1A-41A	• BOLT, SPUD	1
13	BF7840	• REDUCER	2
14	BF7858	• 90° ELBOW	2
15	T0555A	• FUEL LINE PICK UP	2
16	no number	• FUEL FILTER HEAD part of R12P	1
17	R12P	• FUEL FILTER 30 MICRON FILTER	1
17A	R12PS	• FUEL FILTER 2 MICRON FILTER	1
17B	R12PT	• FUEL FILTER 10 MICRON FILTER	1
18	no number	• FUEL FILTER BOWL part of R12P	1



Figure 6-10 • Heat Exchanger

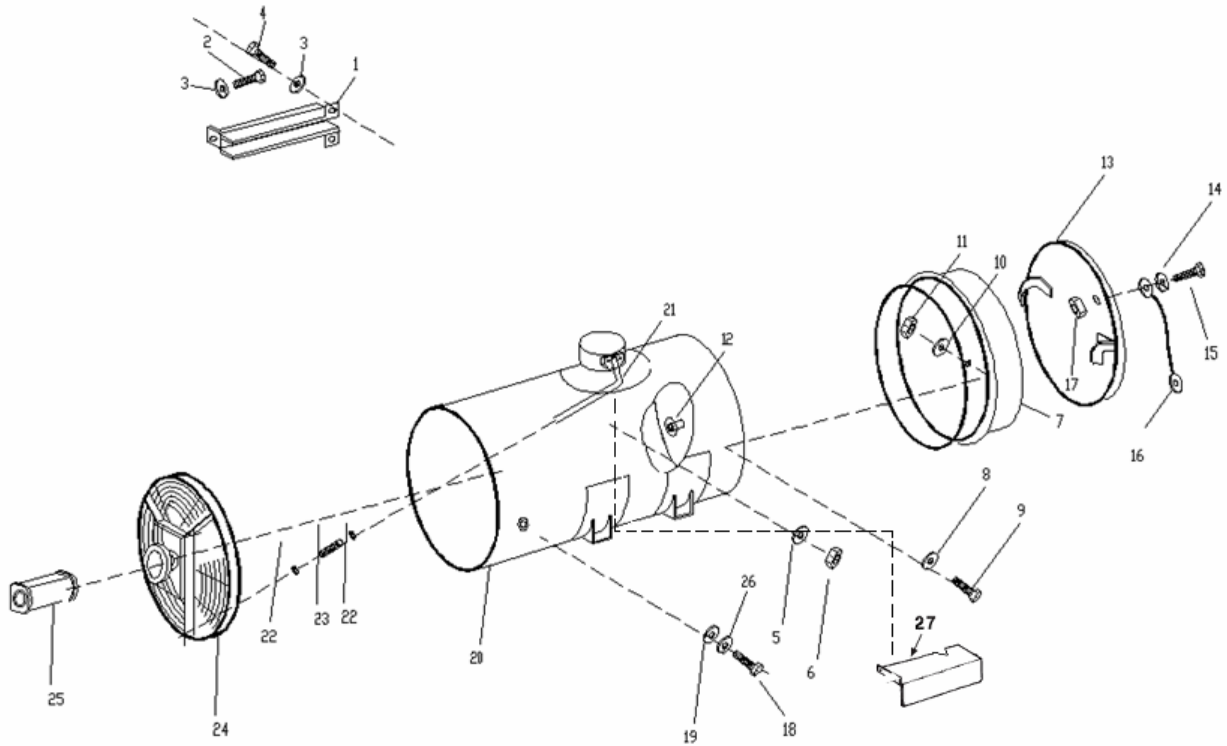



Figure 6-10 • Heat Exchanger



Fig. & Index #	Part #	Description	Units per Ref.
6-10		Heater Assembly	
1	04100183	• SHIELD, CAPILLARY	1
2	SC10	• SCREW 10-24 x 3/8 in.	1
3	WSFT10	• WASHER #10	3
4	SC1024X12MS	• SCREW 10-24 x 1/2 in.	2
5	WSFT10	• WASHER #10	2
6	NT1024KEP	• NUT 10-24	2
7	04040020	• ADAPTER, DUCT, OUTLET	1
8	common	• WASHER	3
9	SC1024X12MS	• SCREW, MACHINE #10-24 x 1/2	3
10	WSFT10	• WASHER #10	3
11	NT1024KEP	• NUT 10-24	3
12	MS35490-37	• GROMMET	3
13	04040011	• COVER, OUTLET	1
14	WSFT10	• WASHER #10	1
15	SC1024X12MS	• SCREW, MACHINE #10-24 x 1/2	1
16	04010165	• CABLE	1
17	NT1024KEP	• NUT-KEP 10-24	1
18	BL14X34	• BOLT 1/4-20 x 3/4 in.	3
19	WSFT14	• WASHER, 1/4 in.	3
20	TAF3166-100	• HEAT EXCHANGER HOUSING (see fig. 6-14 for detailed breakdown)	1
21	TMF3240	• PIPE, EXHAUST	1
22	62020	• CLAMP	2
23	04100155	• HOSE, FLEXIBLE EXHAUST	1
24	04100191	• FAN HUB ASSY (see fig 6-11 for detailed breakdown)	1
25	TM3917-2	• SLEEVE, ENGINE COUPLING	1
26	WSFT14	• WASHER, 1/4 in.	3
27	TCF3241	• EXHAUST SHIELD	1



Figure 6-11 • Fan Hub Assembly

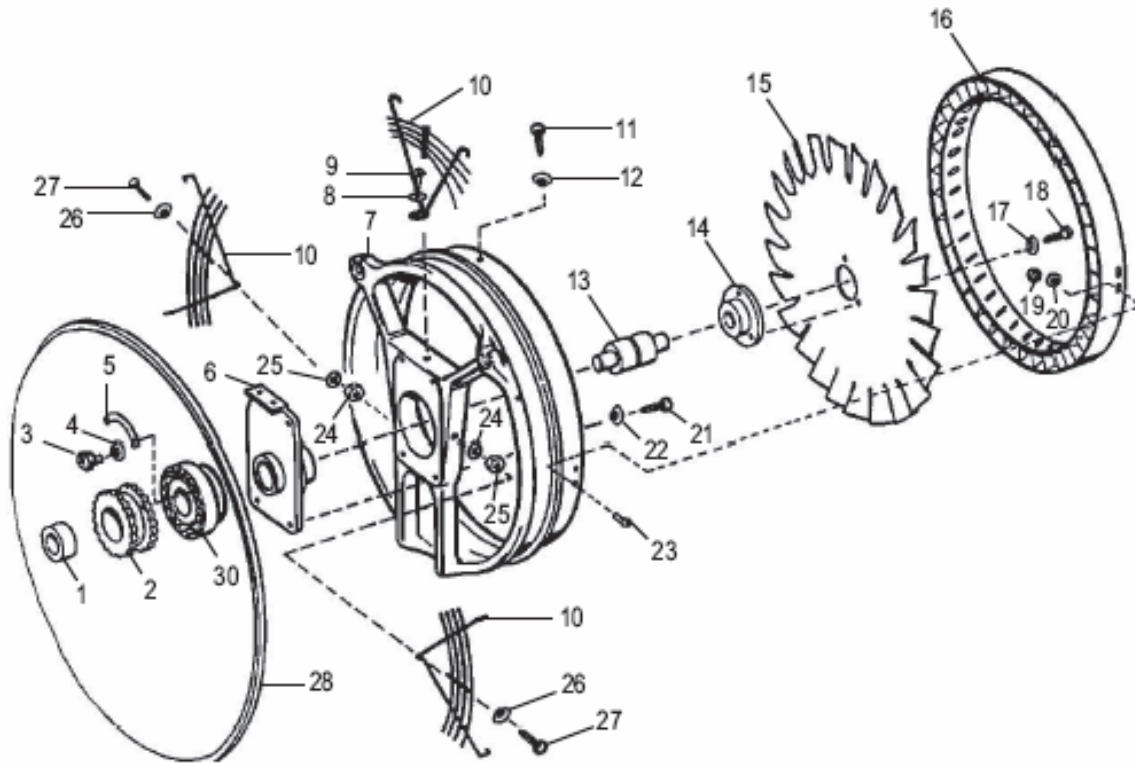



Figure 6-11 • Fan Hub Assembly



Fig. & Index #	Part #	Description	Units per Ref.
6-11		Fun Hub Assembly	
1	TM3927	• BUSHING SLEEVE	1
2	TM3917-2	• SLEEVE, COUPLING FLEX	1
3	SC632X14MS	• SCREW 6-32 x 1/4 in.	4
4	WSFT14	• WASHER 1/4 in.	4
5	TM3959	• RETAINER, COUPLING SLEEVE	2
6	04030002	• SUPPORT, FAN BEARING	1
7	04010017	• FAN RING	1
8	WSFT14	• WASHER FLAT 1/4 in.	1
9	BL14X34	• BOLT 1/4-20 x 3/4 in.	1
10A	04020173	• FAN GUARD - RIGHT	1
10B	04020174	• FAN GUARD - LEFT	1
10C	TMF106	• FAN GUARD - CENTER	1
11	BL14X12	• SCREW, CAP, HEX HD 1/4-20 x 1/2 in.	3
12	WS1NT14	• WASHER, LOCK 1/4 in.	3
13	TM3916	• BEARING, FAN SHAFT	1
14	TM3921	• HUB, FAN	1
15	04040018	• FAN, VANEAXIAL	1
16	04040022	• VANE, AIR STRAIGHTING	1
17	WS1NT14	• WASHER, LOCK 1/4 in.	3
18	BL14X12	• SCREW, CAP, HEX HD 1/4-20 x 1/2 in.	3



Figure 6-11 • Fan Hub Assembly



Fig. & Index #	Part #	Description	Units per Ref.
6-11		Fun Hub Assembly	
19	NT832KEP	• NUT NO. 8-32	2
20	WSFT08	• WASHER, LOCK #8	2
21	MS16997-80	• SCREW, CAP HEX HD 5/16-18 x 1 in.	4
22	WSSR516	• WASHER LOCK 5/16 in.	4
23	SC832X12FH	• SCREW, MACHINE 8-32 x 1/2 in.	2
24	WS1NT14	• WASHER, LOCK 1/4 in.	2
25	NT1420KEP	• NUT, PLAIN HEX 1/4-20	2
26	WSFT14	• WASHER FLAT 1/4 in.	2
27	BL14X112	• SCREW, MACHINE 1/4-20 x 1 1/2 in.	2
28	MS15290	• V-BELT	1



Figure 6-12 • Heat Exchanger Assembly

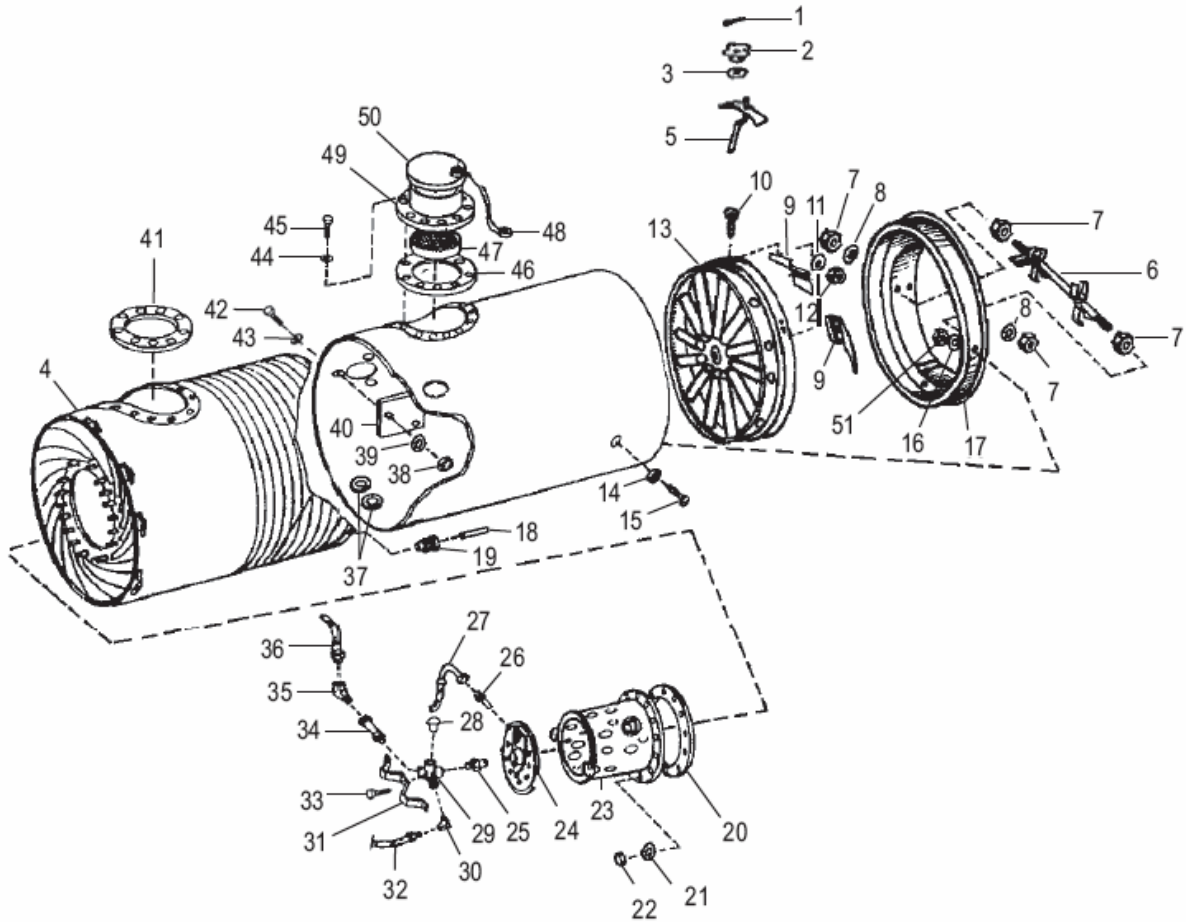



Figure 6-12 • Heat Exchanger Assembly



Fig. & Index #	Part #	Description	Units per Ref.
6-12		Heat Exchanger Assembly	
1	common	• PIN, COTTER 3/32 x 3/4 in.	1
2	TR3343	• HAND WHEEL	1
3	TA3314-1	• WASHER, TEFLON	1
4	TRF3082	• HEAT EXCHANGER	1
5	TAF3158	• CONTROL, DAMPER	1
6	TAF3157	• SUPPORT, BULB AND COIL	1
7	NT1024KEP	• NUT, KEP #10-24	4
8	WSSR10	• WASHER, LOCK #10	2
9	TA235	• BAFFLE, AIR DEFLECTOR	4
10	MS51065-42	• SCREW 10-32 x 3/4 in.	4
11	WSSR10	• WASHER, LOCK #10	4
12	common	• NUT 10-32	4
13	TAF3154	• CONTROL, AIR VOLUME	1
14	WSSR10	• WASHER #10	3
15	SC1024X12MS	• SCREW, MACHINE #10-24 x 1/2	3
16	common	• WASHER #10	3
17	TMF3240	• ADAPTER, DISCHARGE DUCT	1
18	TRF3094	• TUBE DRAIN	1
19	B-600-6-5	• REDUCER, UNION	1
20	TR776A	• GASKET, COMBUSTOR	1



Figure 6-12 • Heat Exchanger Assembly



Fig. & Index #	Part #	Description	Units per Ref.
6-12		Heat Exchanger Assembly	
21	WSFT14	• WASHER, FLAT 1/4 in.	16
22	NT1428NFSLN	• NUT, LOCK, STOVE	16
23	TRF763	• COMBUSTOR	1
24	TRF762	• PLATE, COMBUSTOR	1
25	TR775	• NOZZLE, FUEL	1
26	TE1010B	• PLUG, IGNITER	1
27	04100156	• CABLE, IGNITION	1
28	BF7820	• PLUG	1
29	04010144	• NOLDER, NOZZLE	1
30	BF7808	• ELBOW, PIPE	1
31	T0553C	• CLAMP	1
32	04100157-1	• FUEL, LINE PRESSURE	1
33	SC1032X38MS	• SCREW 10-32 x 3/8 in.	2
34	T0655A	• CHECK VALVE	1
35	BF7814	• 45° ELBOW	1
36	04100157-1	• FUEL LINE, BYPASS	1
37	TE1305	• GROMMET	2
38	NT832KEP	• NUT 8-32	3
39	WSFT08	• WASHER #8	3
40	04100159	• WINDOW, VIEW INSPECTION SHIELD	1



Figure 6-12 • Heat Exchanger Assembly



Fig. & Index #	Part #	Description	Units per Ref.
6-12		Heat Exchanger Assembly	
41	TX595	• GASKET, HEAT EXCHANGER	1
42	SC832X34MS	• SCREW 8-32 X 3/4 in.	3
43	WSFT08	• WASHER #8	3
44	WSFT10	• WASHER #10	12
45	SC1024X34MS	• SCREW 10-24 x 3/4 in.	12
46	TX592	• GASKET, EXHAUST	1
47	04040014	• SPARK ARRESTOR	1
48	04010165	• CABLE	1
49	04040016	• STACK, EXHAUST	1
50	TR3313	• COVER, EXHAUST	1
51	NT1024KEP	• NUT 10-24	3



Figure 6-13 • Fuel Tank Assembly

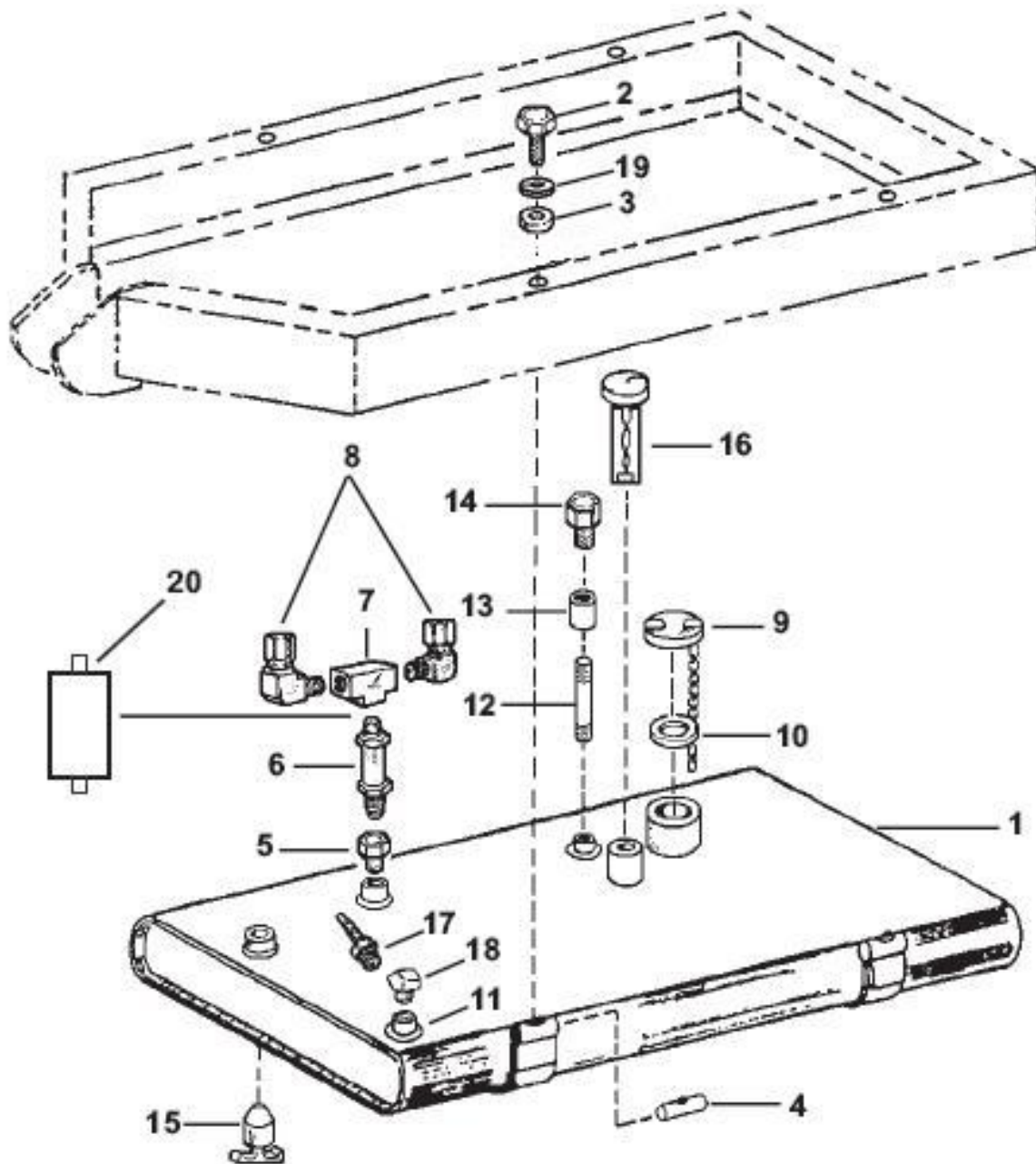



Figure 6-13 • Fuel Tank Assembly



Fig. & Index #	Part #	Description	Units per Ref.
6-13		Fuel Tank Assembly	
1	04100104	• FUEL TANK	1
2	BL3816X1	• BOLT 3/8-16 x 1 in.	4
3	WFL38	• WASHER, FLAT 3/8 in.	4
4	04100142	• BARREL NUT	4
5	BF7824	• FLARE ADAPTER	1
6	TO655A	• CHECK VALVE	1
7	BF7817	• TEE FITTING	1
8	BF7820	• ELBOW	2
9	MS53075-1	• CAP, FUEL TANK	1
10	BF7808	• GASKET, FUEL CAP	1
11	BF7822	• REDUCER	1
12	04100157	• PIPE NIPPLE, 1/4 NPT x 5" VENT PIPE	1
13	BF7838	• UNION	1
14	4796-12	• VENT PLUG	1
15	BF7825	• DRAIN, TANK	1
16	C401V032	• GAUGE, FUEL	1
17	BF7833	• 1/4" HOSE BARB to 1/8 NPT	1
18	BF7808	• 45° ELBOW	1
19	WSSR38	• WASHER LOCK 3/8 in.	4
20	TRA3057-100	FILTER, IN-LINE	1



Figure 6-14 • Trailer & Axle Assembly

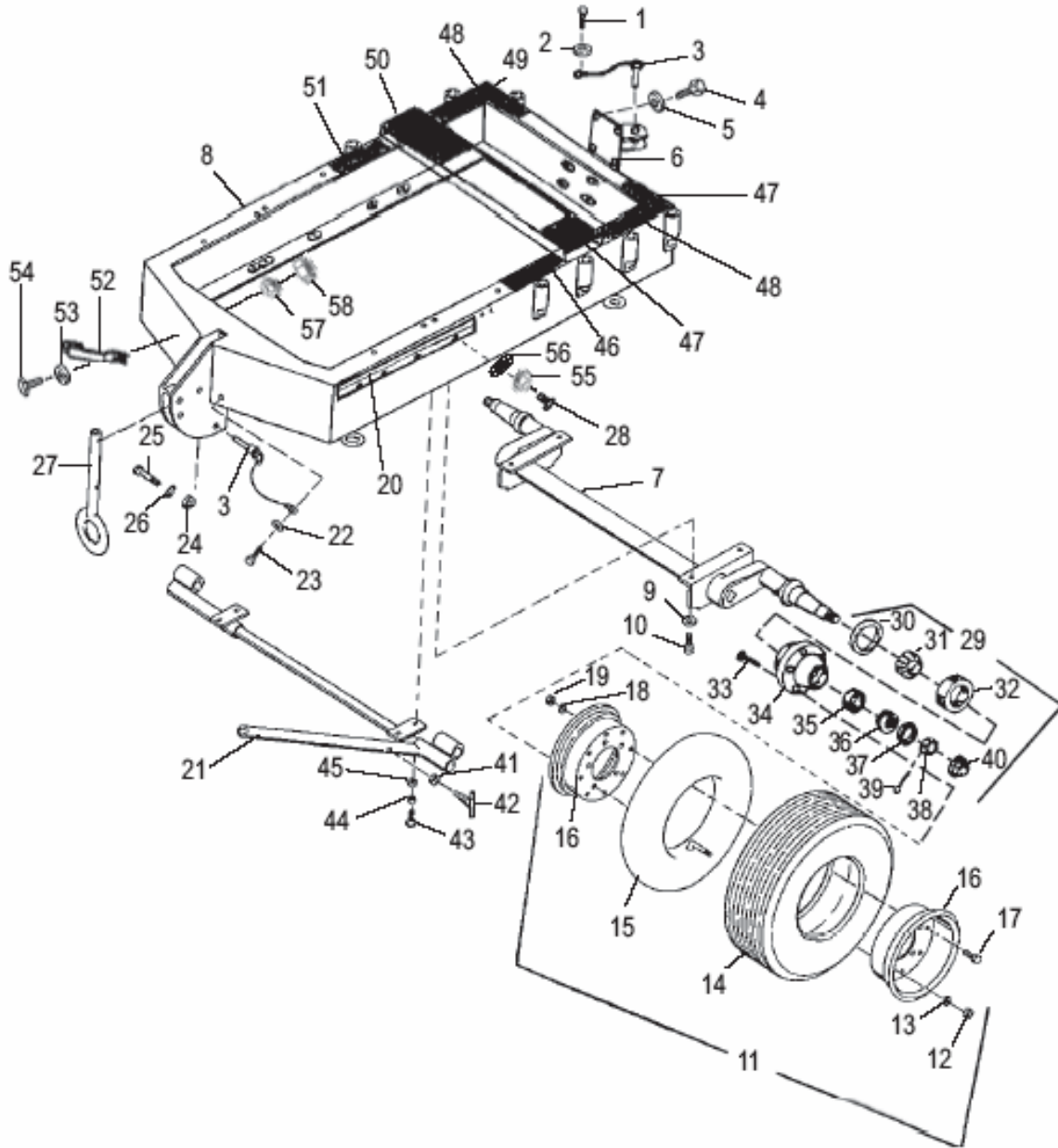



Figure 6-14 • Trailer & Axle Assembly



Fig. & Index #	Part #	Description	Units per Ref.
6-14		Trail & Axle Assembly	
1	common	• BOLT 1/4-20 x 1/4 in.	1
2	common	• WASHER 1/4 in. FLAT	1
3	04020138	• HITCH PIN	2
4	common	• BOLT 1/2-18 x 1 in.	4
5	common	• WASHER FLAT 1/2 in.	4
6	04130033	• TRAILER HITCH	1
7	04130029	• AXLE AND SPRING ASSEMBLY HP2-5206	1
8	05000112	• TRAILER 2-HP2-4614-01	1
9	common	• WASHER FLAT 1/2 in.	4
10	common	• BOLT 1/2-18 x 1 1/4 in.	4
11	no number	• WHEEL ASSEMBLY	2
12	common	• NUT 1/2-20	5
13	common	• WASHER 1/2 in.	5
14	690-G9	• TIRE	2
15	6909	• TUBE	2
16	905-SM-MIL	• RIM OUTER	2
	905-SF-MIL	• RIM INNER	2
17	common	• BOLT 1/2-20 x 3/4 in.	8
18	common	• WASHER 1/2 in.	8
19	common	• NUT 1/2-20	8
20	04130030	• GUIDE, HOOD RETAINER	2



Figure 6-14 • Trailer & Axle Assembly



Fig. & Index #	Part #	Description	Units per Ref.
6-14		Trail & Axle Assembly	
21	05000113	• BRAKE ASSEMBLY 2-HP2-5240	1
22	common	• WASHER 1/4 in.	1
23	common	• BOLT 1/4-20 x 1/4 in.	1
24	common	• NUT 1/2-20	1
25	common	• BOLT 1/2-20 x 2 1/2 in.	1
26	common	• WASHER LOCK 1/2 in.	1
27	04040027-2	• TOW BAR	1
28	common	• BOLT 1/2-18 x 3/4 in.	8
29	no number	• WHEEL HUB ASSEMBLY	2
30	910C104	• SEAL	2
31	24780	• BEARING INNER	2
32	24720	• BEARING, CONE, INNER RACE	2
33	16-5994	• STUD	5
34	MS24328-2	• HUB	2
35	15245	• BEARING, CONE, OUTER RACE	2
36	15123	• BEARING, OUTER	2
37	13108	• WASHER	2
38	AN320-16	• NUT, CASTELLATED	2
39	AN380-4-7	• PIN, COTTER	2
40	A260	• DUST CAP	2



Figure 6-14 • Trailer & Axle Assembly



Fig. & Index #	Part #	Description	Units per Ref.
6-14		Trail & Axle Assembly	
41	HP2-4922	• JAM NUT 5/16-18	1
42	2-HP2-4859	• BRAKE LOCK	1
43	common	• BOLT, HEX HEAD 3/8-16 x 3/4 in.	4
44	common	• WASHER LOCK 3/8 in.	4
45	common	• WASHER 3/8 in.	4
46	04100150-1	• DUCT WEAR STRIP LH	1
47	04100151-1	• DUCT WEAR STRIP	2
48	04100151-2	• DUCT WEAR STRIP	2
49	04100151-1	• DUCT WEAR STRIP	1
50	04100151-2	• DUCT WEAR STRIP	1
51	04100151-4	• DUCT WEAR STRIP RH	1
52	04130023	• HANDLE, LIFT	2
53	common	• WASHER 5/16 in.	4
54	common	• BOLT 5/16-18 x 1 in.	4
55	common	• WASHER LOCK 1/4 in.	8
56	common	• WASHER FLAT 1/4 in.	8
57	common	• WASHER LOCK 5/16 in.	4
58	common	• NUT 5/16-18	4



Section 7



Alphameric index

Part #	Fig. & Index #	Units per	Part #	Fig. & Index #	Units per
04010017	11-7	1	04100104	13-1	1
04010061	3-3	1	04100106	5-3	1
04010104	8-54	1	04100112	4-48	1
04010120	2-15	1	04100114	5-12	1
04010144	12-29	1	04100114	4-47	1
04010152	2-11	2	04100139	4-6	1
04010165	12-48	1	04100142	13-4	4
04010165	10-16	1	04100150-1	14-46	1
04010205	2-17	1	04100151-1	14-49	1
04010207	2-1	1	04100151-1	14-47	2
04010209	2-16	1	04100151-2	14-50	1
04010211	2-5	2	04100151-2	14-48	2
04010212	2-6	2	04100151-4	14-51	1
04020138	14-3	2	04100155	10-23	1
04020173	11-10	1	04100156	12-27	1
04020174	11-10	1	04100156	4-49	1
04030002	11-6	1	04100157	13-12	1
04040011	10-13	1	04100157-1	12-36	1
04040014	12-47	1	04100157-1	12-32	1
04040016	12-49	1	04100157-1	8-51	1
04040018	11-15	1	04100157-1	6-9	1
04040020	10-7	1	04100157-1	6-2	1
04040022	11-16	1	04100157-1	5-4	1
04040027-2	14-27	1	04100159	12-40	1



Alphameric index

Part #	Fig. & Index #	Units per	Part #	Fig. & Index #	Units per
04100172	8-27	1	05000119	4-4	1
04100175	8-19	1	05000120	3-12	1
04100178	8-12	1	05000121	3-2	1
04100179	4-3	4	05000122	3-15	2
04100183	10-1	1	05000123	3-9	2
04100191	10-24	1	05000124	3-13	2
04100199	5-8	1	05000125	2-10	1
04100199	5-8	1	05000126	2-8	1
04100371	5-15	1	05000127	2-7	1
04110198	5-9	1	05000128	2-3	2
04110199	2-4	3	05000129	2-9	1
04110224	3-7	1	05000130	2-14	2
04110229	2-13	1	05000134	2-2	1
04130013	8-52	1	05000135	4-30	1
04130023	14-52	2	05000136	4-31	1
04130024-2	4-29	8	05000137	4-32	1
04130029	14-7	1	05000138	4-33	1
04130030	14-20	2	05000139	3-19	1
04130033	14-6	1	05000140	3-1	4
05000112	14-8	1	05000141	3-11	1
05000113	14-21	1	05000142	2-12	1
05000114	4-22	1	05000145	4-34	1
05000117	4-39	1	05000146	4-44	1
05000118	4-5	1	05000148	6-7	1



Alphameric index

Part #	Fig. & Index #	Units per	Part #	Fig. & Index #	Units per
0510009-2	5-3	1	121222	7-34	1
0510009-3	5-3	1	121732	7-33	1
0510011-1	5-21	1	123632	7-19	1
0510011-2	5-21	1	123652	7-21	1
0510011-3	5-21	1	1271131	7-9	1
05100141	4-38	5	127297	7-12	1
100241	7-24	1	127297	7-11	1
100371	7-25	1	127297	7-10	1
100901	7-29	2	127297	7-8	1
100931	7-30	1	127297	7-7	1
101001	7-26	1	127297	7-6	1
101641	7-31	1	127562	7-22	1
103379	7-27	1	13108	14-37	2
105021	7-5	1	131196	7-37	1
110441	7-3	1	131199	7-23	1
111302	7-4	1	131201	7-13	1
111401	7-2	8	13130	4-43	1
113331	7-14	1	15123	14-36	2
114227	7-28	1	15245	14-35	2
115462	7-20	1	1615DC	7-18	1
116106	7-32	1	16-5994	14-33	5
117463	7-1	1	1A-25A	9-1	1
118732	7-15	1	1A-26A	9-6	1
120R	9-1	1	1A-27B	9-10	1



Alphameric index

Part #	Fig. & Index #	Units per	Part #	Fig. & Index #	Units per
1A-28A	9-9	1	AN320-16	14-38	2
1A-30	9-8	1	AN380-4-7	14-39	2
1A-31A	9-7	1	B-600-6-5	12-19	1
1A-33	9-2	1	BF7808	13-18	1
1A-37	9-11	1	BF7808	13-10	1
1A-38	9-4	1	BF7808	12-30	1
1A-39	9-5	1	BF7808	6-11	2
1A-41A	9-12	1	BF7809	6-14	1
1A-58	9-3	2	BF7810	6-10	1
20018-1	4-45	1	BF-7810	8-45	3
24720	14-32	2	BF7814	12-35	1
24780	14-31	2	BF7814	6-16	1
28778	7-35	1	BF7817	13-7	1
2-HP2-4859	14-42	1	BF-7817	8-46	1
4796-12	13-14	1	BF-7819	8-48	3
51295	7-16	3	BF7820	13-8	2
62020	10-22	2	BF7820	12-28	1
6909	14-15	2	BF7822	13-11	1
690-G9	14-14	2	BF7823	7-36	1
80057	5-20	1	BF7823	6-8	1
905-SF-MIL	14-16	2	BF7824	13-5	1
905-SM-MIL	14-16	2	BF7825	13-15	1
910C104	14-30	2	BF7827	6-15	1
A260	14-40	2	BF-7827	8-47	1



Alphameric index

Part #	Fig. & Index #	Units per	Part #	Fig. & Index #	Units per
BF7833	13-17	1	EVL-13984	8-44	1
BF7838	13-13	1	EVL-14260	8-40	1
BF7840	9-13	2	EVL-18080	8-38	1
BF7842	5-13	1	EVL-22772	8-37	1
BF7858	9-14	2	EVL-42310	8-42	2
BF7874	5-14	1	EVL-54165	8-41	1
BL12X114	6-4	2	EVL-63224	8-43	1
BL14X112	11-27	2	HP2-4922	14-41	1
BL14X12	11-18	3	L48EEDEAH	4-46	1
BL14X12	11-11	3	MIL-M-39711-1	8-1	1
BL14X134	4-23	4	MS15290	11-28	1
BL14X134	4-1	4	MS16997-80	11-21	4
BL14X34	11-9	1	MS171591	8-53	1
BL14X34	10-18	3	MS171591	8-33	1
BL14X34	4-41	2	MS24328-2	14-34	2
BL14X34	4-11	2	MS24523-22	8-8	1
BL3816X1	13-2	4	MS24523-30	8-4	2
BL38X112	5-19	4	MS29513-016	8-36	2
BL516X112	4-26	4	MS29513-112	8-35	2
BL516X134	4-35	5	MS29513-116	8-56	1
BL516X34	4-17	4	MS35490-37	10-12	3
BL516X34	4-14	4	MS51065-42	12-10	4
C401V032	13-16	1	MS53075-1	13-9	1
EVL-13483	8-39	1	NT1024KEP	12-51	3



Alphameric index

Part #	Fig. & Index #	Units per	Part #	Fig. & Index #	Units per
NT1024KEP	12-7	4	SC1024X12MS	3-18	2
NT1024KEP	10-17	1	SC1024X12MS	3-16	4
NT1024KEP	10-11	3	SC1024X12MS	3-6	3
NT1024KEP	10-6	2	SC1024X1MS	5-11	3
NT1024KEP	3-17	4	SC1024X34MS	12-45	12
NT1024KEP	3-14	5	SC1024X34MS	3-10	5
NT1032KEP	4-10	2	SC1032X38MS	12-33	2
NT1420KEP	11-25	2	SC1420X34FH	4-40	2
NT1420KEP	4-13	2	SC632X14MS	11-3	4
NT1428NFSLN	12-22	16	SC632X34MS	3-4	2
NT38HN	5-17	4	SC832X12FH	11-23	2
NT516NLN	4-7	2	SC832X34MS	12-42	3
NT632KEP	3-8	3	T0539A	8-50	1
NT632KEP	3-5	2	T0539A	8-30	1
NT832KEP	12-38	3	T0540A	8-32	1
NT832KEP	11-19	2	T0542	8-34	2
R12P	9-17	1	T0553C	12-31	1
R12PS	9-17	1	T0555A	9-15	2
R12PT	9-17	1	T0555A	6-13	1
SC10	10-2	1	T0555A	6-12	2
SC1024X12MS	12-15	3	T0574C	8-18	1
SC1024X12MS	10-15	1	T0586E	8-17	1
SC1024X12MS	10-9	3	T0587C	8-15	1
SC1024X12MS	10-4	2	T0653A	8-16	3



Alphameric index

Part #	Fig. & Index #	Units per	Part #	Fig. & Index #	Units per
T0653A	6-6	1	TMF3240	10-21	1
T0655A	12-34	1	TMF3240	4-50	1
T0F64C	8-28	1	TO655A	13-6	1
TA218A	4-20	4	TR3269	8-20	1
TA235	12-9	4	TR3274	8-31	1
TA3314-1	12-3	1	TR3275	8-49	1
TAF3154	12-13	1	TR3275	8-29	1
TAF3157	12-6	1	TR3276	8-14	1
TAF3158	12-5	1	TR3277	6-1	1
TAF3166-100	10-20	1	TR3313	12-50	1
TCF3241	10-27	1	TR3343	12-2	1
TE1010B	12-26	1	TR775	12-25	1
TE1305	12-37	2	TR776A	12-20	1
TM3916	11-13	1	TRA3057-100	13-20	1
TM3917-2	11-2	1	TRF3082	12-4	1
TM3917-2	10-25	1	TRF3094	12-18	1
TM3917-2	5-7	1	TRF762	12-24	1
TM3917-3	5-8	1	TRF763	12-23	1
TM3919	6-5	1	TS623	8-13	1
TM3921	11-14	1	TX592	12-46	1
TM3927	11-1	1	TX595	12-41	1
TM3959	11-5	2	WFL38	13-3	4
TMF106	11-10	1	WS1NT14	11-24	2
TMF3240	12-17	1	WS1NT14	11-17	3



Alphameric index

Part #	Fig. & Index #	Units per	Part #	Fig. & Index #	Units per
WS1NT14	11-12	3	WSFT14	4-12	2
WS1NT38	5-16	4	WSFT14	4-2	4
WSFT08	12-43	3	WSFT38	5-18	4
WSFT08	12-39	3	WSFT38	4-37	5
WSFT08	11-20	2	WSFT516	4-19	4
WSFT10	12-44	12	WSFT516	4-9	2
WSFT10	10-14	1	WSSR06	7-17	3
WSFT10	10-10	3	WSSR10	12-14	3
WSFT10	10-5	2	WSSR10	12-11	4
WSFT10	10-3	3	WSSR10	12-8	2
WSFT10	8-55	1	WSSR10	3-20	2
WSFT10	5-10	3	WSSR14	4-27	4
WSFT10	3-21	2	WSSR14	4-24	4
WSFT12	6-3	2	WSSR38	13-19	4
WSFT12	4-21	as required	WSSR38	4-36	5
WSFT14	12-21	16	WSSR516	11-22	4
WSFT14	11-26	2	WSSR516	4-18	4
WSFT14	11-8	1	WSSR516	4-15	4
WSFT14	11-4	4	WSSR516	4-8	2
WSFT14	10-26	3			
WSFT14	10-19	3			
WSFT14	4-42	2			
WSFT14	4-28	4			
WSFT14	4-25	4			