

FROST *Fighters*

INDIRECT FIRED SPACE HEATERS



**MODEL IDF350-II
MODEL IDF500
(AUGUST 2008-
PRESENT)**

**Installation - Operation/Maintenance
Instructions and Parts List**

READ INSTRUCTIONS PRIOR TO STARTING HEATERS



AEROTECH HERMAN NELSON INTERNATIONAL INC

**100 EAGLE DRIVE
WINNIPEG, MANITOBA
CANADA R2R 1V5**

**PHONE: +1 (204) 633-1999
FAX: +1 (204) 694-1612**

WWW.HERMANNELSON.COM

TOLL FREE: 1-800-486-4328

**ISO 9001:2008
Certified System**



FROSTFIGHTER WARRANTY

I.C.E. Mfg. Ltd. warrants the Frostfighter heater to be free from defects in workmanship and materials for a period of twelve (12) months from date of initial service not to exceed fifteen (15) months from date of shipment.

If during the warranty period, the heat exchanger fails under normal use and service due to a defect in material or workmanship said heat exchanger will be repaired or replaced free of charge F.O.B. the Winnipeg Factory..

All mechanical and electrical components are covered by a one (1) year limited warranty. Normal maintenance items are excluded under the warranty. The warranty does **NOT** include any freight, labor or sales taxes incurred by the purchaser and is subject to the following conditions:

1. The heater shall be operated in accordance with the manufacturer's operating and maintenance manual.
2. The heater shall be subject to normal use in service and shall not have been misused, neglected, altered or otherwise damaged.
3. The unit shall be operated within the rated capacities and with the prescribed fuel.
4. The unit has not been allowed to exceed its proper temperature limits due to control malfunction or inadequate air circulation.
5. There is no evidence that the unit has been subject to tampering or deliberate destruction.
6. The heat exchanger shows no signs of an implosion or explosion.

No representative of I.C.E. Mfg. Ltd., nor any of its distributors or dealers, is authorized to assume for I.C.E. Mfg. Ltd. any other obligations or liability in connection with this product, nor alter the terms of the warranty in any way. This warranty is limited to the express provisions contained herein and does not extend to liability for labor costs incurred in replacing defective parts.

Parts can be obtained from I.C.E. Mfg. Ltd., Winnipeg, Manitoba on the basis that credit will be issued if the defective parts returned qualify for replacement pursuant to the terms and conditions of this warranty. Authorization to return any alleged defective parts must be first obtained from the factory prior to transporting the part. A R.G.A.# must be provided from an ICE representative. The transportation charges for the alleged defective part must be prepaid by the owner. I.C.E. Mfg. Ltd. will not accept charges for parts purchased unless the conditions of this warranty have been satisfied and prior authorization to purchase the parts has been received from the factory.



AEROTECH HERMAN NELSON INTERNATIONAL INC



100 EAGLE DRIVE WINNIPEG, MANITOBA

CANADA R2R 1V5

PHONE: +1 (204) 633-1999

FAX: +1 (204) 694-1612

SPECIFICATIONS

| MODEL | IDF350-II | IDF500 | IDF500HS |
|------------------------------|---|---|---|
| MAXIMUM INPUT | 350,000 BTU/HR | 500,000 BTU/HR | 500,000 BTU/HR |
| NOZZLE SIZE | 2.00 USGPH 45' B (SOLID) | 2.50 USGPH 60'B (SOLID) | 2.50 USGPH 60'B (SOLID) |
| PUMP PRESSURE | 125 P.S.I. MAXIMUM | 140 P.S.I. MAXIMUM | 140 P.S.I. MAXIMUM |
| FUEL TANK CAP. | 35 IMP GALS. 42 US GALS. | 35 IMP GALS. 42 US GALS. | 35 IMP GALS. 42 US GALS. |
| ELECTRICAL SUPPLY | 115 VOLT 15 AMP | 115 VOLT 20 AMP | 115 VOLT 25 AMP |
| HEATED AIR (W/O DUCT) | 2500 CFM | 3100 CFM | 3500 CFM |
| APROX. RUN TIME | 13 HOURS | 11 HOURS | 11 HOURS |
| APPROVAL AGENCY |  |  |  |
| DRY WEIGHT | 510 LBS. | 510 LBS. | 510 LBS. |

Flue size-6" on all units

NOTE: -These heaters are intended for use primarily as temporary heating of buildings under construction, alteration or repair

| MAXIMUM ALLOWABLE DUCT LENGTHS (IDF 350 & IDF 500) | |
|---|---------|
| DISCHARGE OUTLET | LENGTH |
| Two 12" ducts | 24 Feet |
| One 16" duct | 45 Feet |

For the IDF500 HS, the maximum allowed ducting is 50' for the 12" X 2 and 100' for the 16".

Dimensions of IDF350-II and of the IDF500 Heaters

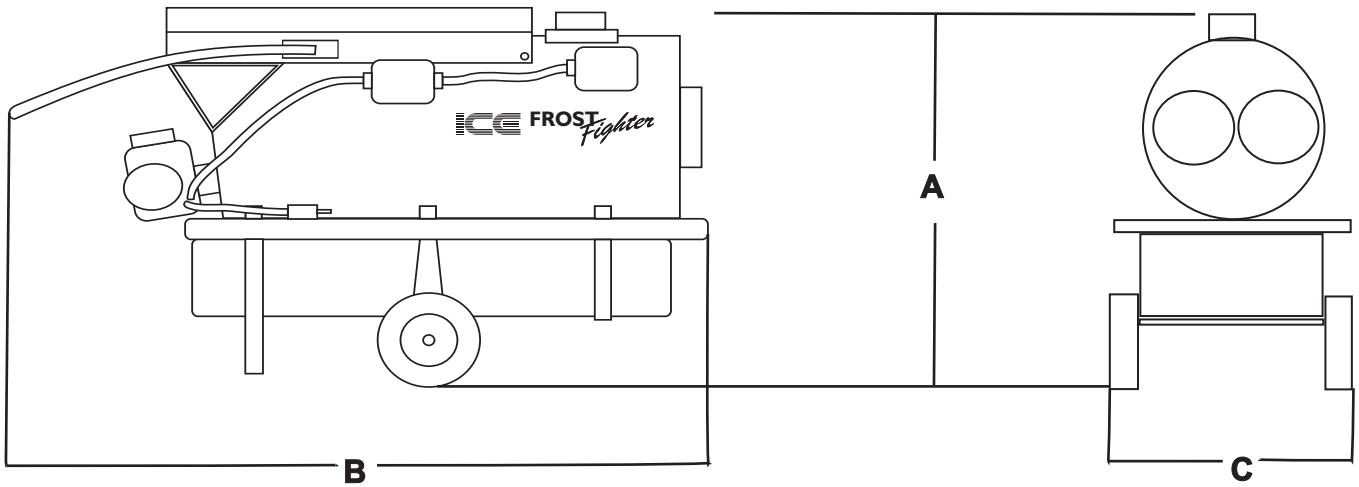

| Heater Only | | | | | With Packaging | | | |
|-------------|-----|---------|-----|--------------|----------------|-----|---------|--------------|
| MODEL | A | B | C | WEIGHT (LBS) | L | W | H | WEIGHT (LBS) |
| IDF350 | 51" | 76 1/2" | 27" | 510 | 83" | 38" | 52 1/2" | 562 |
| IDF500 | 51" | 76 1/2" | 27" | 510 | 83" | 38" | 52 1/2" | 562 |

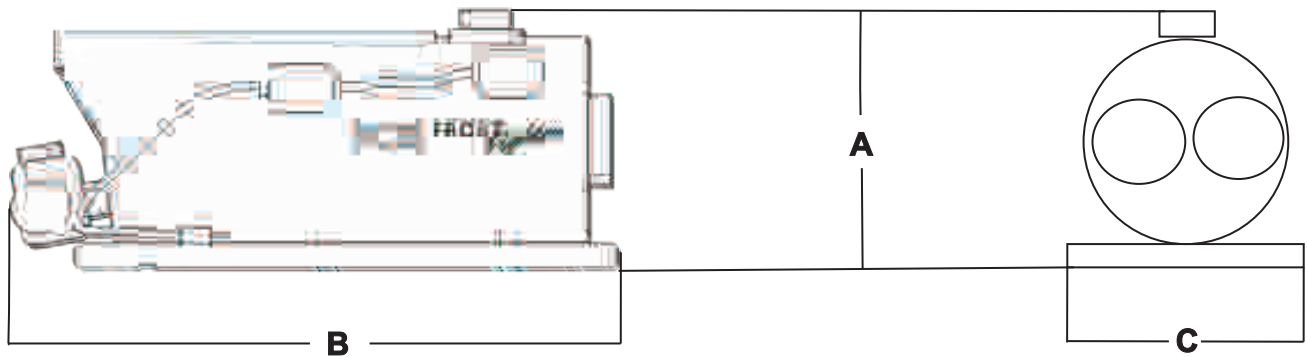

| Heater Only | | | | | With Packaging | | | |
|-------------|---------|---------|-----|--------------|----------------|-----|---------|--------------|
| MODEL | A | B | C | WEIGHT (LBS) | L | W | H | WEIGHT (LBS) |
| IDF350 | 29 1/2" | 65 1/2" | 25" | 325 | 70 1/2" | 32" | 35 1/4" | 375 |
| IDF500 | 29 1/2" | 65 1/2" | 25" | 325 | 70 1/2" | 32" | 35 1/4" | 375 |

INSTALLATION INSTRUCTIONS

1. The recommendations of local authorities having jurisdiction must be followed. For recommended Installation practices refer to C.S.A. Standard B139 (CANADA) or NFPA 54 (US)
2. When firing the unit in an enclosed area 3 square feet must be provided to allow the free entry of the air required for operation.
3. For electrical supply, use 3 wire receptacle with "U" ground.
4. Do not operate the unit in partly ventilated areas without a flue pipe or in close proximity to combustible surfaces or materials.

NOTE: Installation clearances are as follows:

Top - 3 inches
Sides - 6 inches
Burner End - 2 feet

Discharge End - 10 feet
Vent Connector - 18 inches
Floor - Combustible

FLUE PIPE CONNECTIONS

When the heater is connected to a flue pipe the flue pipe shall terminate in a vertical section at least two feet long. Horizontal runs should have rise ratio of 1 in 10 away from the heater. The chimney should have .02" W.C. draft to ensure safe operation of the unit. Where down drafts are liable to occur a vent cap should be used. All venting Should correspond with the CSA B149 (CANADA), NFPA 54 (US) standard or local codes.

INSTALLATION CLEARANCES

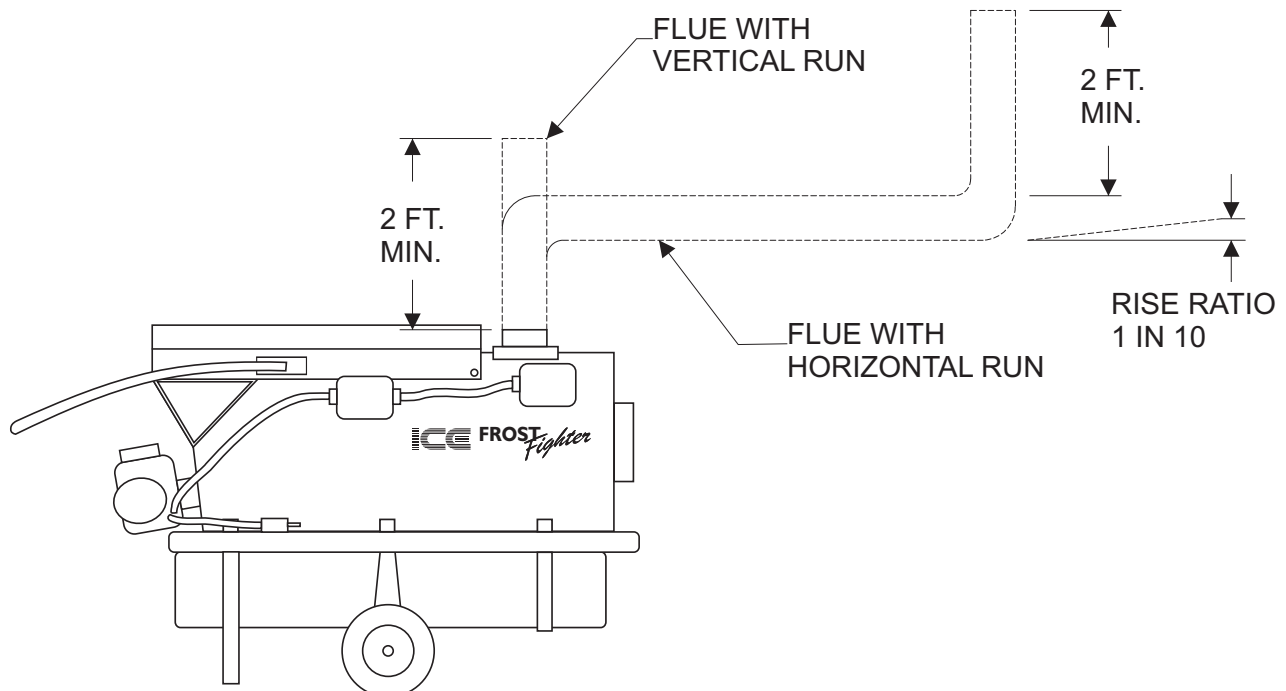

OPERATING INSTRUCTIONS

TO START HEAT WITH HONEYWELL CONTROL

1. Ensure unit is on flat, level ground before starting, canopy and fan guards must be closed.
2. Flip switch to "OFF" position
3. Check fuel level (2-4 gallons to start)
4. Plug in supply cord to 115 volt outlet.
5. Flip switch to "MANUAL" position.
6. For thermostat operation flip switch to "THERM" position.
7. There will be a 5 second safe start check, a 15 second pre purge then the burner will fire.

TO START HEATER WITH GENISYS CONTROL

- 1-6 same as above
7. There will be a 5 second safe start, 45 second pre purge then the burner will fire. On shutdown there is a 2 minute post purge.

IF HEATER FAILS TO START

1. Press manual reset button on burner relay.
2. Check for low voltage condition and 115 volt supply.
3. Check fuel filter, suction tubing and nozzle assembly

NOTE: If unit has been reset a number of times without ignition there will be an accumulation of oil in the combustion chamber! Do the Following:

1. Make sure unit is sitting on level ground to ensure excess oil drain out of secondary exchanger (via small drain hole located on outer shell of heat exchanger by burner end).
2. Allow unit to drain for 15-20 minutes or until all oil has drained out.
3. Upon ignition excessive amounts of smoke will be present until all excess oil has been burnt from the heat exchanger.
4. When the unit has stabilized and the burner set up to operate properly, shut off the switch. Let the fan cool down the chamber and stop.

IF UNIT STILL DOES NOT START REFER TO THE TROUBLE SHOOTING GUIDE PAGE 12

CAUTION

1. Do not start heater when excess oil has accumulated in chamber.
2. Do not fill tank while unit is operating.
3. Do not shut off by disconnecting supply cord. The heat exchanger should be properly cooled before power shutdown.
4. In no case should extension cords be smaller than 12 A.W.G. If cord is longer than 50' use 10 A.W.G. minimum.
5. Do not use gasoline, crankcase oil or heavier than No. 2 furnace oil.
6. Always maintain adequate fuel supply.

ELECTRICAL REQUIREMENTS:

15 amp circuit IDF 350-II
20 amp circuit IDF 500
25 amp circuit IDF 500HS

TO STOP HEATER

Flip switch to "OFF" position. The supply fan will continue to operate until the heat exchanger has sufficiently cooled. Do not disconnect main power until supply fan has stopped running.

WARNING!: BEFORE MOVING ANY GUARDS OR SAFETIES DISCONNECT THE MAIN POWER AS THE SUPPLY FAN WILL CYCLE AUTOMATICALLY.

IDF MAINTENANCE INSTRUCTIONS

!WARNING!: Heaters should be fully serviced annually to ensure proper Performance. Maintenance should be performed by trained personnel only. Incorrect maintenance may result in improper operation and serious injury.

HIGH LIMIT SWITCH

The limit switch should be checked every heating season to ensure the burner will shutdown if temperature exceeds 220° F. (This can be done by restricting the air flow through the unit. After tests are complete, remove restricters as both 12" ducts must be open for proper operation).

FAN SWITCH

The fan switch has been selected to allow for preheating of the heat exchanger to ensure that only heated air is allowed to enter the space. Upon satisfying the need for heat, the fan switch will continue to run the supply fan until the heat exchanger has cooled sufficiently. This feature will help prolong the life of your heat exchanger.

FUEL FILTER

Replace cartridge (48164 or 48164A) once every week of normal usage or sooner, depending upon fuel quality.

FLAME DETECTOR

When doing maintenance, turn on machine. After having run the machine run for over 10 seconds, press red button on primary control. Hold for one second and then release. If light flashes once or twice, cad cell is functioning properly. If flashes three times, check alignment and proper flame. If correct a cleaning of the face of the cad cell with a soft non abrasive cloth is recommended. If light flashes four times, follow above steps. If flashing four times persists, replace cad cell.

LED FLASHES

1
2
3
4

CAD CELL RESISTANCE

0-400 Ohms
400-800 Ohms
800-1600 Ohms
>= 1600 Ohms

BURNER

The electrode spacing must be checked and adjusted, if necessary after every nozzle change. Nozzle should be replaced annually or sooner if burner cannot be set up to operate properly. Nozzle size and type are marked on the rating plate.

ELECTRICAL

Ensure all conduit (BX) connectors are tight. Check inside connections in control box to ensure good connections. Check marrettes.

FAN

Check for dust or dirt build up on blades. Check for tightness of the set screw. Run heater to check for fan vibration. Replace fan blade if vibration is noticeable.

MOTORS

No lubrication is necessary since the bearings are the sealed type. Clean motor of existing dust or dirt.

FUEL SYSTEM

Periodically remove fuel tank drain plug and clean tank. Do not store unit containing furnace oil for long periods. **The quality of fuel oil will affect light off at low ambient temperatures, #1 fuel oil or kerosene are recommended for temperatures below -10° C / 8° F.** (see page 7 for recommended settings if using #2 fuel oil in cold temperature)

FUEL PUMP

Check fuel pump pressure on a regular basis. This should be checked at the bleeder screw. **WITH THE CLEAN CUT PUMP ADD 10 LBS TO THIS READING TO GET THE TRUE PRESSURE.**

There is a pressure loss when fuel passes through solenoid valve. Example: IDF350 pressure should be read on the guage at 135 PSI, reading at nozzle line will then be 125. Units with the Suntec A2YA7916, pressure reading can be checked at the guage port. This will provide a true reading.

HEAT EXCHANGER

If a smokey condition continues even after adjusting the air band assembly, the heat exchanger should be thoroughly cleaned as per next page.

CLEANING PROCEDURE

1. Remove front cap. (48205, 48205A or 20205)
2. Remove cover panel (jacket to front). (48119 or 20119)
3. Remove fan thermostat cover on outer jacket (the one nearest the burner). (48112A)
Loosen thermostat and remove from the jacket. Remove high limit thermostat cover.(48112). Remove the two screws that are on jacket, at the 3'o'clock & 9 o'clock position 8 inches from front of unit.
4. Slide heat exchanger out of jacket and place front face down on floor.
5. Access for combustion chamber and heat exchanger cleaning is obtained through the burner head opening and by removing the heat exchanger cap ring(s) (48115 or 50115).
6. To reassemble, reverse procedure. If you need assistance, please contact the factory.

Close canopy and ensure fan guards are in proper position before trying to restart the unit..

COMBUSTION AIR ADJUSTMENTS

****For proper combustion air adjustment a calibrated gas analyzer and smoke tester should be used to ensure complete combustion. Air adjustment should be made at the correct input and be adjusted to achieve 10% CO₂. For optimum combustion efficiency the combustion air control should be set to provide no more than a No. 1 smoke (Bacharach Scale). The Beckett burner has a calibrated air band, which will assist in adjusting the primary air for a good oil/air mixture. Adjust air band supply by loosening lock screws and moving air shutter (B48254) and if necessary the bulk air band. Begin by reducing the air until the unit begins to produce smoke. Increase air until no smoke is produced. Check for excessive heat build up in the heat exchanger. Insufficient air will cause flame impingement and reduced heat exchanger life. Increase air until heat build up has been eliminated. Check for proper ignition. Once satisfied re- tighten all screws and locking mechanisms.

This adjustment is to be carried out while the unit is operating and after 5 minutes of firing. Rotating the air bands on the burner housing makes the adjustment.

| AIR SETTINGS | | | |
|--------------|---------|------|--------------|
| UNIT MODEL | SHUTTER | BAND | BURNER MODEL |
| OHV200 | 10 | 4 | CF 375 |
| IDF 350 | 10 | 6 | CF 375 |
| IDF 350-II | 6.0 | 6.0 | CF 500 |
| IDF 500 | 10 | 0 | CF 800 |

***Note: The above settings are approximations based upon clean equipment in proper working order. Combustion air adjustments will vary with location, altitude and type of fuel used.

Due to the increased density of #2 oil at colder temperatures, kerosene fuel must be used or he oil nozzle change as follows at temperatures below 8°F/-10°C.

| | |
|------------------|-----------------------|
| Model | Nozzle (USGPH) |
| OHV350 | 1.5 x 60' R Monarch |
| IDF350/IDF350-II | 1.75 X 45'B Delevan |
| OHV500 | 2.25 x 60' R Monarch |
| IDF500 | 2.25 X 60'B Delevan |

TEMPERATURE FEELER ADJUSTMENT: (Attached to fan switch)

ALWAYS MAKE SURE THAT THE TEMPERATURE FEELER IS TOUCHING THE HEAT EXCHANGER!!

The temperature feeler provides air flow over the fan switch, which regulates the cycling of the fan. The temperature feeler can be adjusted for different outside temperatures, by rotating the location of the temperature feeler holes. This will provide optimum performance of the unit in different applications, and will reduce or eliminate unnecessary fan cycling.

IF SURROUNDING AIR IS WARM (EG., -5 C or 23 F, indoor application):

TURN THE TEMPERATURE FEELER SO THAT THE HOLES ARE PARALLEL WITH THE HEAT EXCHANGER, AND ENSURE THAT NOTHING IS BLOCKING THE AIR FLOW (EG., SCREWS). BY DOING THIS THE FAN SWITCH WILL REMAIN COOL AND NOT OVERHEAT. (SEE FOLLOWING)
The fan switch is located under the high limit/fan cover which is mounted on the jacket close to front of unit. The switch can be adjusted by using a flat-headed screw driver and turning it clockwise or counter clockwise to desired temperature.

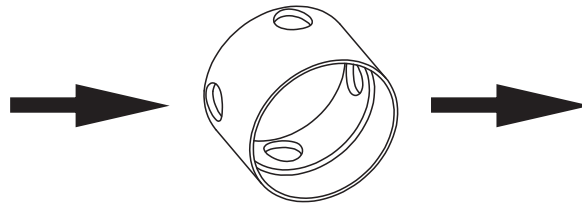

IF SURROUNDING AIR IS COLD (EG., under -5 C or 23 F)

TURN THE TEMPERATURE FEELER SO THAT THE HOLES ARE CLOSED OFF AS THE AIR GOES OVER THE HEAT EXCHANGER, THIS WILL REDUCE FAN CYCLING, UNIT SHUTDOWN, ETC. (SEE FOLLOWING)

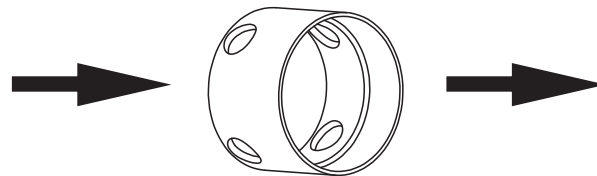

Indoor and outdoor settings of fan switch

Indoors & if surrounding air is warm i.e. -5C/23F-Fan switch should be set to 115' or higher so as to shut down unit when heat exchanger is properly cooled, also keeps fan motor from excessive running on when discharging cooler air.

Outdoor-Fan switch should be set between 100'-90'. The colder the temperature the lower the setting.

ELECTRODE SETTINGS FOR IDF350-II & IDF500 MODELS

- Check, and adjust if necessary, the critical dimensions shown in *Figure 5*. Verify that the oil tube assembly and electrodes are in good condition, with no cracks or damage.

Figure 5 - Nozzle and nozzle line assembly

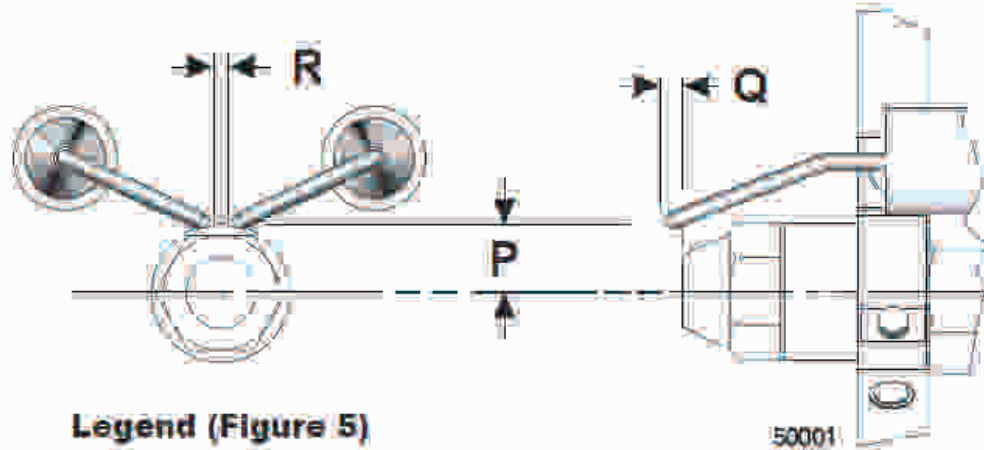

Legend (Figure 5)

- P** Nozzle centerline to electrode tip = $3/16''$
- Q** Nozzle face to electrode tip = $1/4''$
- R** Electrode spacing = $3/16''$ gap

SLIDE PLATE SETTINGS FOR IDF350-II & IDF500 MODELS

Figure 7 - Adjusting plate assy.

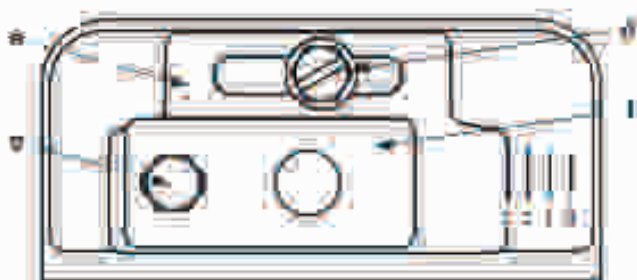

Legend (Figure 7)

- a** Electrode seat
- b** Fastener
- c** Primary adjusting plate
- f** Secondary adjusting plate

**IDF350-II
IDF500**

**4-5
6**

JUNCTION BOX OF IDF350-II, IDF500 & IDF500HS

48184 CLEAR COVER FOR 48185B
HONEYWELL CONTROLLER
48188 CLEAR COVER FOR 50144
GENISYS CONTROLLER

48216 15 AMP BREAKER
REPLACES FUSE & FUSE
HOLDER

48165
THERMOSTAT
RECEPTACLE

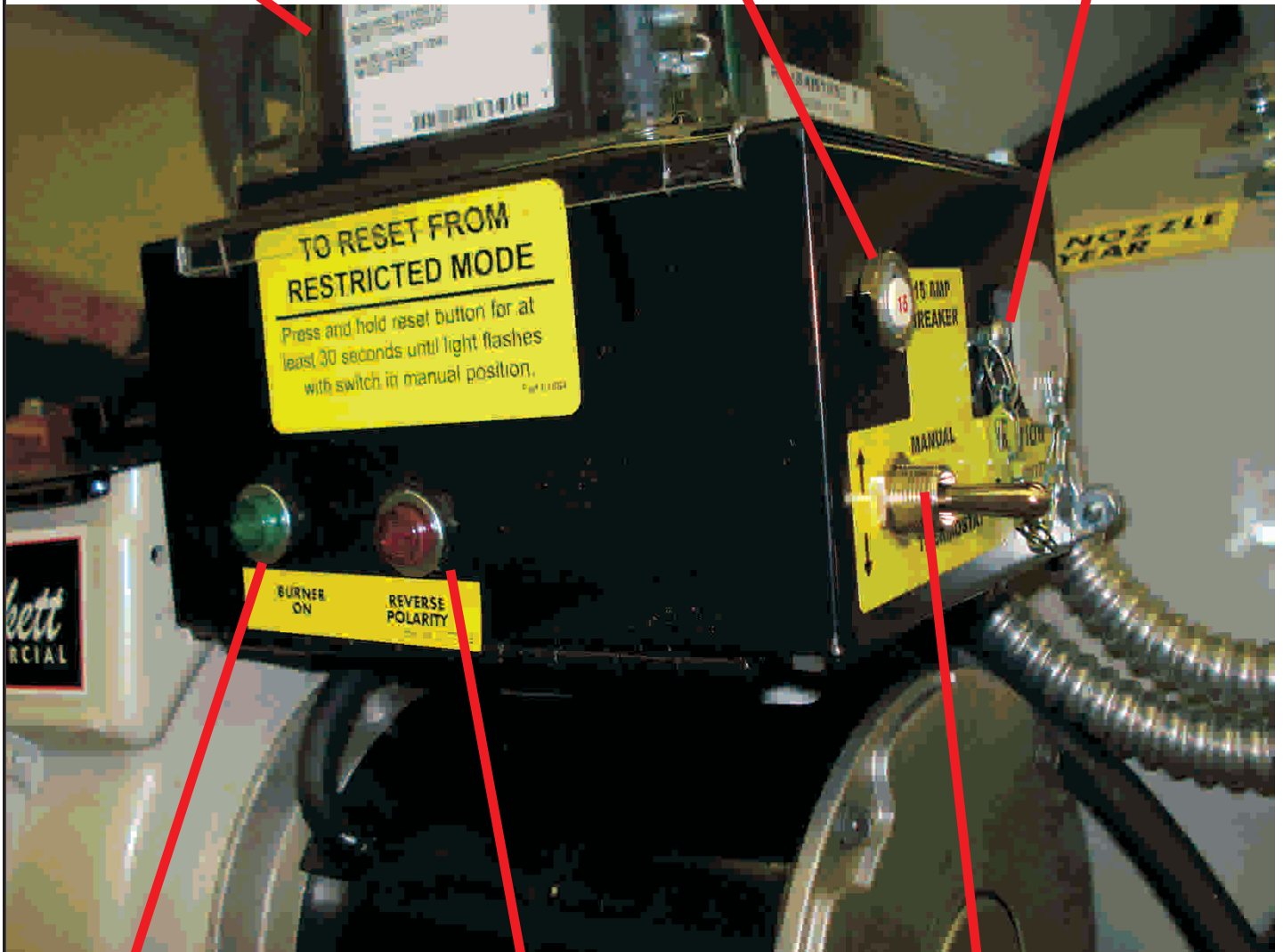

48006 GREEN LIGHT
W/LEADS

48005 RED LIGHTS
W/LEADS

48160
TOGGLE
SWITCH

THE SETTING OF THE “Z” DIMENSION ON IDF350-II & IDF500 MODELS

□ Install nozzle line assembly

- Insert the nozzle line assembly into the burner air tube. Reference *Figure 6*.
- Slide the secondary adjusting plate (*Figure 7*, item *f*) completely to the left on the indicator adjusting plate (item *e*). Finger tighten acorn nut (item *c*) to secure the two plates together. Slide both plates completely to the right (Indicator Plate will read 0). Tighten fastener (item *d*).
- Install the spline nut on the end of the nozzle line, leaving the nut loosely placed so the plates can be moved.

Figure 6 - Nozzle Line assembly in burner

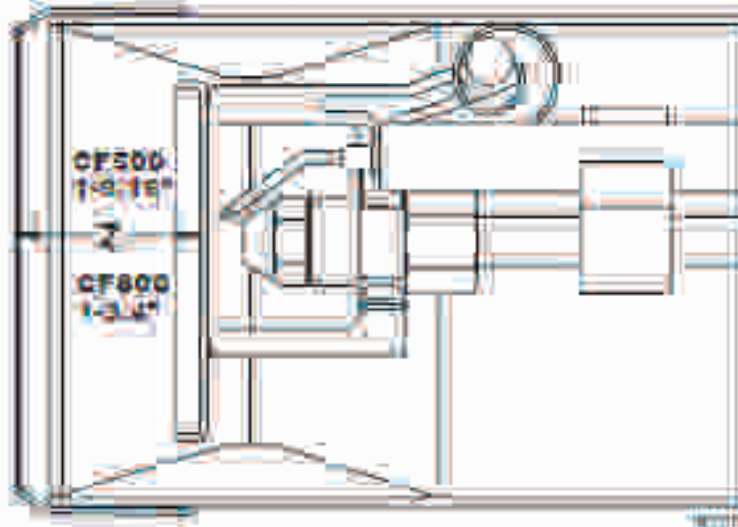

□ Set dimension Z

1. **Lower Access** in Figure 1. Slide the nozzle line and plate assembly until dimension Z of Figure 6 is:
 - CF500: 1.9/16" = 11.6
 - CF800: 1.5/16" = 10

When dimension Z (from end of blade to the face of front face of head) is correctly set, tighten acorn nut (item *c*).
2. Attach the oil line from the oil valve to the nozzle line end. Tighten securely.
3. Before proceeding, check dimension Z once again. Loosen acorn nut if necessary to reposition the nozzle line. Once dimension Z is set, do not loosen the acorn nut again. Note that for the setting of pressure of valves, Initial Head Determining Measure on Page 11.

IDF/OHV TROUBLE SHOOTING GUIDE

ALWAYS DOUBLE CHECK FOR SUFFICIENT POWER , GAUGE OF CORD (SEE TOP OF PAGE #5) AND PROPER FUEL SUPPLY. POWER AND FUEL SUPPLY MUST BE SHUT OFF/DISCONNECTED BEFORE REMOVING OR REPLACING ANY COMPONENTS ON THE HEATER.

- 1. Unit is turned on, nothing happens after 5 second safe start.**
 - a. Ensure proper voltage coming in, 115V AC.
 - b. Check for power on both sides of burner fuse. If no power, then check toggle switch. If power on one side, replace fuse. If power on both sides, go to **c**.
 - c. Check black wire from primary control. If no power there, remove high limit cover & check for power on both sides of high limit. If power on one side only, replace high limit. If power on both sides, go to **d**.
 - d. Ensure thermostat contacts on primary control (T and T) are jumpered out.
 - e. Make sure light on primary control is not flashing. If so, push button to reset.
 - f. Check manual reset button on motor and wiring connection to motor. If reset pushed and power going to motor, nothing is happening, replace burner motor.
 - g. On neutral line (white wires) make sure all connections are tight and secure, and unit is properly grounded. With AC voltage tester, check white (neutral lines) for power (one on ground, one on neutral). If over 5 volts, check polarity. If polarity correct, check wires individually for power to determine leak source, then replace leak source.
 - h. If power coming into black wire on primary control, but no power out to orange wire, replace primary control.
 - i. If green light on primary control stays on, check to ensure transformer door is closed properly as cad cell is detecting light. Check cad cell is working. If light stays on and no obvious areas open, check OHM reading across two yellow wires. If you get a reading, replace cad cell. If you get no OHM reading from cad cell, replace primary control if light still on.
- 2. Burner motor starts but unit will not fire.**
 - a. Check for power on blue wire on primary control going to ignitor. If no power there, replace primary control if powered, go to **b**.
 - b. Remove electrode assembly and check isolators for cracks or chips in the porcelain. Make sure electrode setting is proper. For electrode adjustments, please turn to page 9.Clean assembly if there is any soot or oil..
 - c. The nozzle should be checked and ensure it is not clogged or blocked. Make sure nozzle is not loose.
 - d. Ensure air shutters are properly set to factory specifications.
 - e. Check for power on violet line on primary control. After pre-purge, if no power sent to violet line, replace primary control. If power on violet line, remove copper fuel line at electrode assembly to ensure fuel is coming out. If no fuel there, replace solenoid valve.
 - f. At the bleeder screw, check for proper out pump pressure (see maintenance section). If low or no pump pressure, go to **g**
 - g. Check oil filter, oil pick up tube and oil lines to ensure free flow and they are not clogged or dirty.
 - h. Check electrical polarity and grounding.
- 3. Burner fires then locks out.**
 - a. Check oil pressure to ensure solenoid valve is opening. Check oil flow system, filter, pick up tubes and lines.
 - b. The nozzle should be checked to ensure it is clean and emitting a good spray pattern, as this could affect the cad cell operation.
 - c. Cad cell (flame detector) could be defective. Disconnect yellow cad cell wires from primary control. Start unit and when it fires, connect jumper across connections on primary control. If unit continues to run, then check cad cell alignment with burner, clean face with a soft cloth and ensure no external light is affecting it. With an ohmmeter, check resistance across cad cell leads with machine running and primary control cad cell leads jumpered out. If resistance over 1200 OHMS, cad cell should be replaced. If unit locks out with jumper, replace primary control.

IDF TROUBLE SHOOTING GUIDE

3.
 - d. Wires between cad cell and primary control should be checked to see that they are not pinched or crimped..
 - e. Prime fuel pump by loosening bleeder screw till steady stream of fuel comes out to ensure no air or bubbles in fuel line..
 - f. **If unit locks out three times in succession, it will go into restricted lock out mode. To reset, hold down reset button for 45 seconds until LED flashed twice. The unit will then resume in normal operating mode.** After verifying primary control is not in lockout & light continues to flash, replace primary control.
 - g. Check polarity, ground & voltage must be between 108-132v AC.
 - h. Make sure high limit is functioning properly.
4. **Smoky fire**
 - a. Check nozzle, make sure is tight and not clogged.
 - b. Check combustion chamber for cracks or burnt out.
 - c. Check air band settings. (Air shutter and/or air band may be closed too much-restricting combustion air.
 - d. Check pump pressure.
 - e. Check slide plate to make sure it is in correct position.(See page 9 for settings)If necessary, open slightly.
 - f. Check recommended settings if using #2 fuel in cold ambient teMperatures
5. **Delayed ignition**
 - a. Check for proper electrode setting.
 - b. Check the isolators for cracks or a conducting coat of soot or oil. Cracks sometimes occur under the electrode bracket, causing a short circuit.
 - c. Check to see that the air shutter is not overly open-too much air will blow out flame.
 - d. Check to ensure pump pressure is properly set..
 - e. Change nozzle.
 - f. Check fuel filter, replace if necessary.
 - g. Ensure that draft or wind is not blowing out flame-add 3' stack.
6. **Main fan will not come on, unit shuts down on high limit.**
 - a. Check temperature feeler, make sure it is in properly.
 - b. Jumper out fan switch to test motor. If you have voltage to motor and still does not start, replace motor. Check line voltage to ensure proper voltage. Also checks amp draw on motor, motor may be running too hot and not run due to thermal overload being tripped.
 - c. Replace fan switch if you have power on one side after unit heating up it does not make
 - d. Replace high limit as it may be tripping too soon and not giving fan switch time to engage.
 - e. Ensure fan switch temperature is correct for weather conditions (see page 8 for settings)
7. **Unit on, but cycles on high limit**
 - a. Check air flow, ensure both ducts are in place and clear of obstruction and straight.
 - b. Check pump pressure, unit could be over firing.
 - c. Check nozzle that proper size of nozzle is installed.
 - d. Change high limit.
 - e. **Maximum duct length with 2 X 12" outlet is 24' on each side. 1 X 16" outlet , length is 45'. Any longer will create back pressure in the unit and trip the high limit. *SEE PAGE 2 FOR SPECS***
 - f. Fuel type- #2 will increase BTU output @cold ambient temperatures resulting in overheating.
8. **Combustion chamber turns red.**
 - a. Nozzle may be firing side ways (replace or adjust)
 - b. Clogged nozzle (replace)
 - c. Temperature feeler not on properly or missing (Must be touching heat exchanger)
 - d. High limit not functioning (replace)
 - e. Excessive pump pressure. Check and reset if necessary
 - f. Fuel type-see page 7 for recommended settings.

Sequence of Operation of Honeywell R7184B Primary Control

- 1. STANDBY.** The burner is idle, waiting for a call for heat. When a call for heat is initiated, there is a 5 second delay while control performs a safe start check.
- 2. VALVE-ON DELAY.** The ignition and motor are turned on for a 15 second valve on delay. During this delay, the blower will circulate air through the heat exchanger, purging what any fumes that may have collected.
- 3. TRIAL FOR IGNITION (TFI)** The fuel valve is opened. A flame should be established within the 15 second lockout time
- 4. LOCKOUT** If flame is not sensed by the end of the TFI, the control shuts down on safety lockout and must be manually reset. If the control locks out three times in a row, the control enters restricted lockout. To reset , hold down reset button for 45 seconds until LED flashes twice.
- 5. IGNITION CARRYOVER** Once flame is established, the ignition remains on for 10 seconds to ensure flame stability before turning off.
- 6. RUN** The burner runs until the call for heat is satisfied. The burner is then shut down and sent to standby.
- 7. RECYCLE** If the flame is lost while the burner is firing, the control shuts down the burner, enters a 60 second recycle delay, and then repeats the above ignition sequence. If flame is lost three times in a row, the control locks out to prevent cycling with repetitious flame loss due to poor combustion.

DISABLE FUNCTION

Any time the motor is running, press and hold the reset button to disable the burner. The burner will remain off as long as the button is held and will return to standby when released.

LED INDICATOR KEY

| LED | STATUS |
|--|-------------------------------|
| On | Flame sensed |
| Off | Flame not sensed |
| Flashing (½ second on, ½ second off) | Lockout/Restricted Lockout |
| Flashing (2 second on, 2 second off) | Recycle |

Sequence of Operation for Genisys Controller



Burner States

Standby:

The burner is idle, waiting for a call for heat.

Valve-On Delay:

The igniter and motor are on while the control delays turning on the oil

solenoid valve for 45 seconds..

Trial For Ignition:

The oil solenoid valve is energized. A flame should be established within the factory set trial for ignition time ("lockout time").

Lockout:

The control has shut down for one of the following safety reasons:
a. The trial for ignition (lockout) time expired without flame being established.

b. The cad cell detected flame at the end of the Valve On Delay state.

To reset the control from lockout click the button 1-second.

NOTE: A recurrence of the above failure modes or a failed welded relay check could cause the control to enter a Hard Lockout state that must be reset only by a qualified service technician. To reset from Hard Lockout, hold the reset button for 15 seconds until the yellow light turns on.

Ignition Carryover:

Once flame is established, the igniter remains on to ensure flame stability.

Run:

The flame is sustained until the call for heat is satisfied. The burner is then sent to Motor-Off Delay, if applicable, or it is shut down and sent to Standby.

Recycle:

If the flame is lost while the burner is firing, the control shuts down the burner, enters a 60 second recycle delay, and repeats the ignition sequence. The control will continue to Recycle each time the flame is lost, until it reaches a pre-set time allotment. The control will then go into Hard Lockout instead of recycle. This feature prevents excessive accumulation of oil in the appliance firing chamber.

Motor-Off Delay:

If applicable, the oil solenoid valve is turned off and the control delays turning the motor off for the set motor-off delay time before the control returns to standby.

Pump Prime:

The igniter and motor are on with the oil solenoid valve energized for 4 minutes. During Pump Prime mode, the cad cell is disregarded, allowing the technician to prime the pump without having to jumper the cad cell.

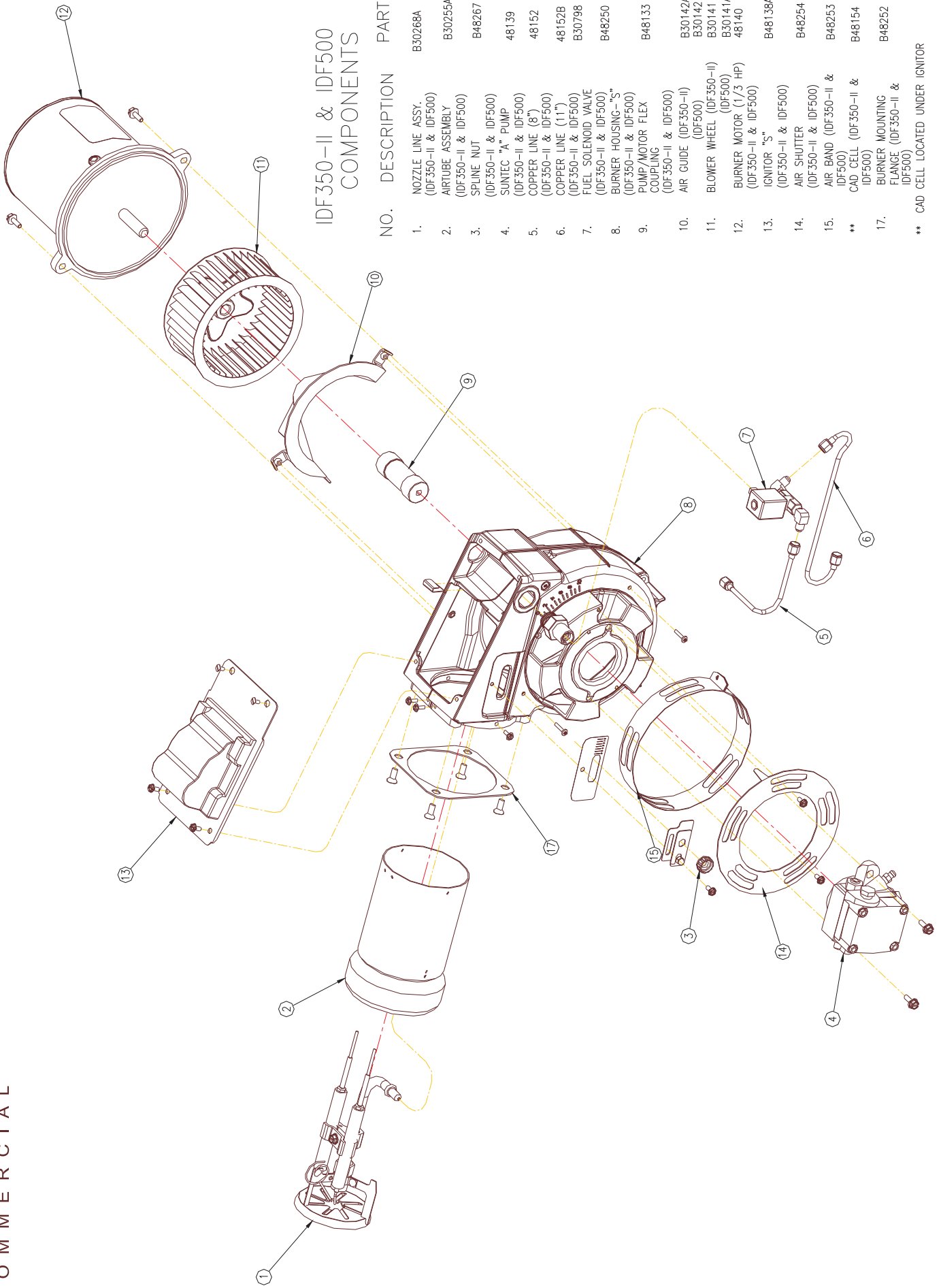

IDF350-II & IDF500 COMPONENTS

| NO. | DESCRIPTION | PART |
|-----|---|----------------------------|
| 1. | NOZZLE LINE ASSY. (IDF350-II & IDF500) | B30268A |
| 2. | AIR TUBE ASSEMBLY (IDF350-II & IDF500) | B30255A |
| 3. | SPLINE NUT (IDF350-II & IDF500) | B48267 |
| 4. | SUNTEC "A" PUMP (IDF350-II & IDF500) | 48139 |
| 5. | COPPER LINE (8") (IDF350-II & IDF500) | 48152 |
| 6. | COPPER LINE (11") (IDF350-II & IDF500) | 48152B |
| 7. | FUEL SOLENOID VALVE (IDF350-II & IDF500) | B30798 |
| 8. | BURNER HOUSING-"S" (IDF350-II & IDF500) | B48250 |
| 9. | PUMP/MOTOR FLEX COUPLING (IDF350-II & IDF500) | B48133 |
| 10. | AIR GUIDE (IDF350-II) (IDF500) | B30142A B30142 |
| 11. | BLOWER WHEEL (IDF350-II) (IDF500) | B30141A B30141 48140 |
| 12. | BURNER MOTOR (1/3 HP) (IDF350-II & IDF500) | B48138A |
| 13. | IGNITOR "S" (IDF350-II & IDF500) | B48254 |
| 14. | AIR SHUTTER (IDF350-II & IDF500) | B48253 |
| 15. | AIR BAND (IDF350-II & IDF500) | B48154 |
| ** | CAD CELL (IDF350-II & IDF500) | B48252 |
| 17. | BURNER MOUNTING FLANGE (IDF350-II & IDF500) | |

** CAD CELL LOCATED UNDER IGNITOR

PRIMARY CONTROLS USED ON OHV HEATERS **(PAST & PRESENT)**



48185 WHITE ROGERS
THIS CONTROL HAS INSTANT LIGHT OFF (NO PRE PURGE) AND CONTINUOUS SPARK.

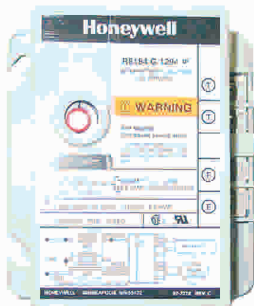

48185A-R8184 HONEYWELL
SAME OPERATION AS THE WHITE ROGERS CONTROL.



48185B-R7184B HONEYWELL
THIS IS THE LATEST PRIMARY THAT HAS BEEN USED SINCE 2004. THERE IS TWO DIFFERENT MODELS THAT HAVE BEEN IN PRODUCTION, THE SERIES 4 & THE SERIES 5. THE SERIES 4 HAD WIRES ONLY COMING OUT OF THE BOTTOM OF THE CONTROL. THIS CONTROL IS NO LONGER AVAILABLE & WAS REPLACED WITH THE SERIES 5. THE SERIES 5 HAS TERMINAL SPADES INSTEAD OF WIRES FOR EASE OF REPLACING. WHAT IS REQUIRED FOR CONVERSION IS A STANDOFF (P/N 48000)

IDF350-II & 500 WIRING DIAGRAM WITH HONEYWELL CONTROL

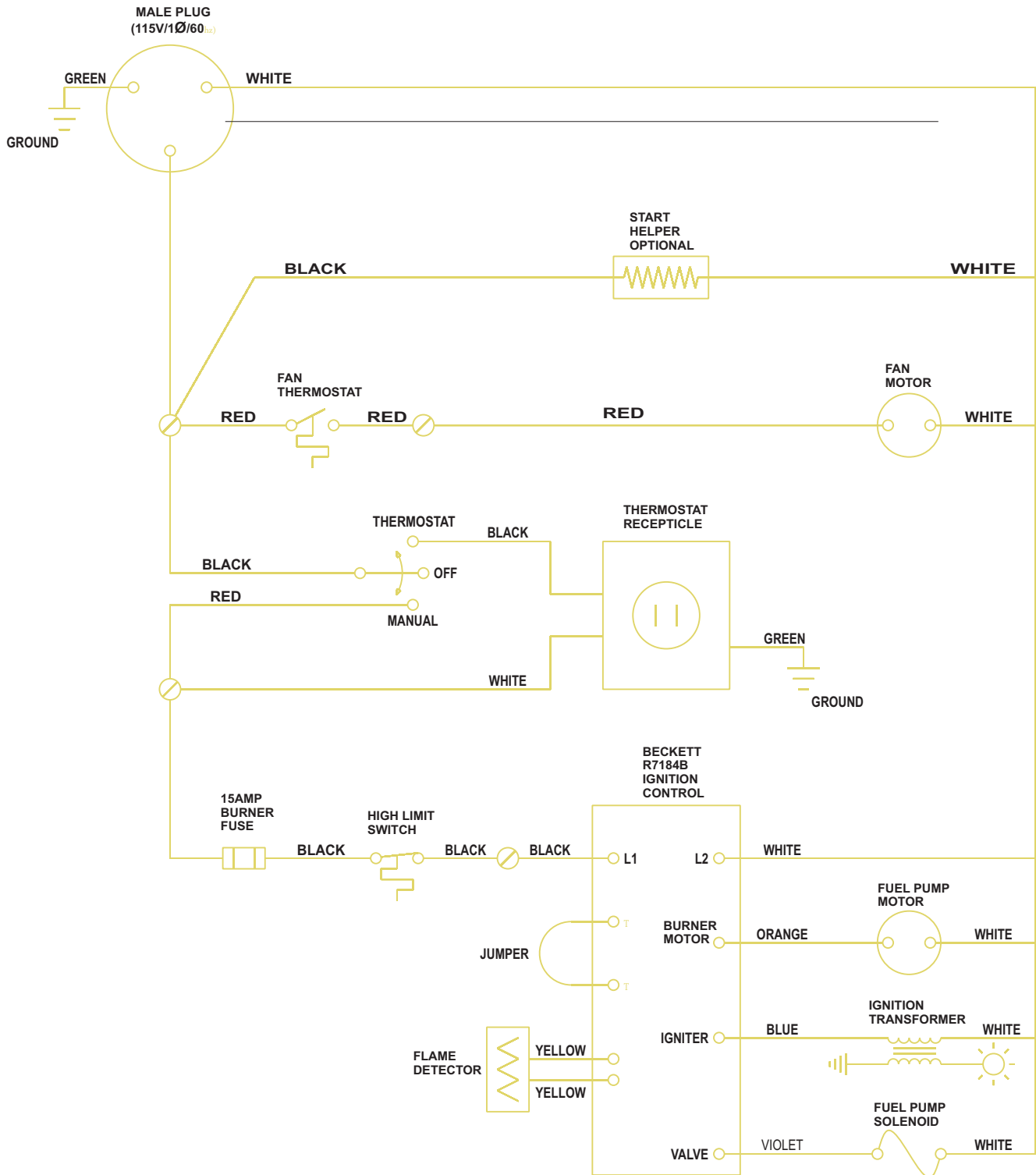

IDF 350 & 500 WIRING DIAGRAM WITH GENISYS CONTROL

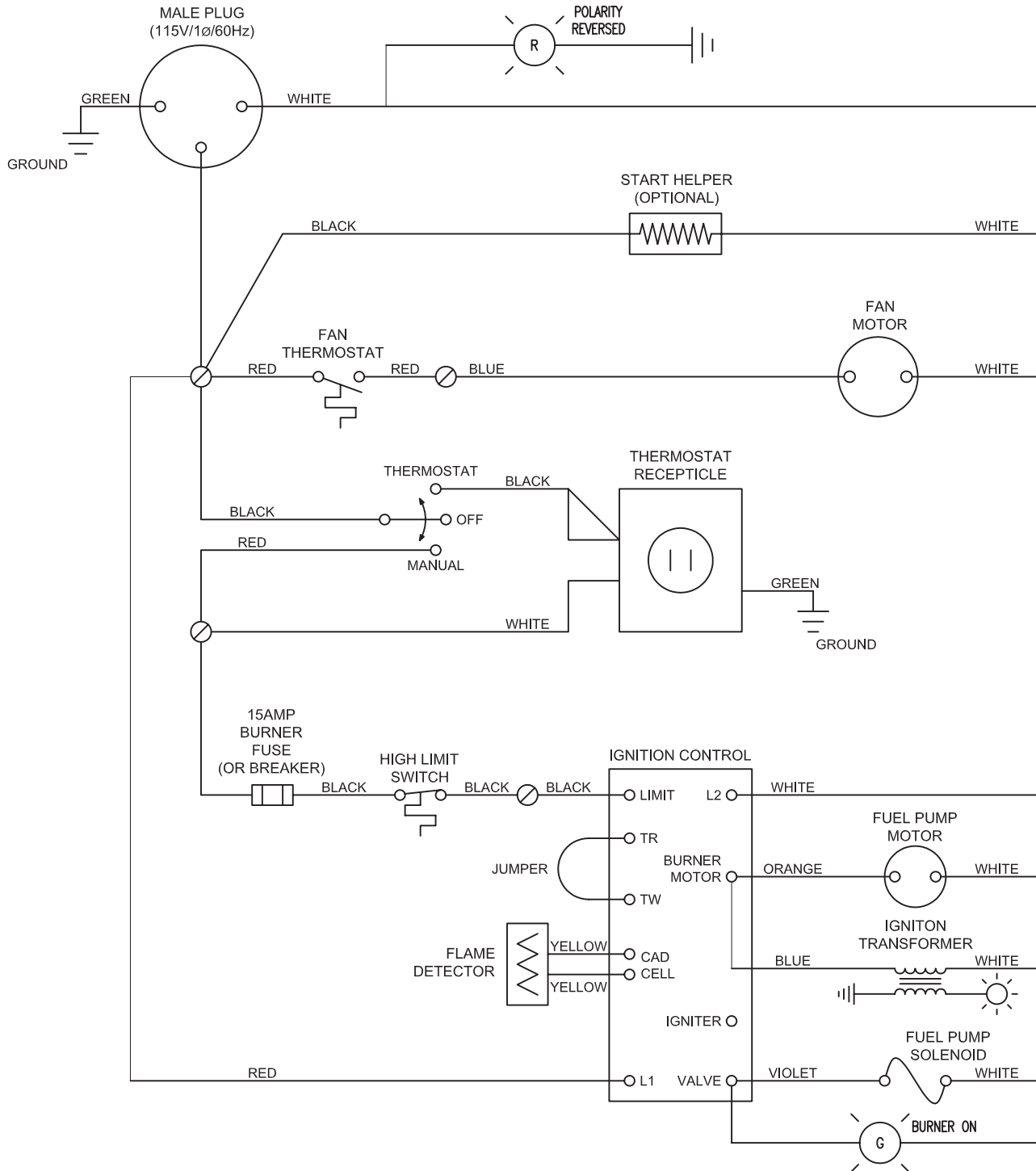

**IDF350-II & IDF500
CF BURNER
ELECTRODE ASSEMBLY
(PART #B20268)**

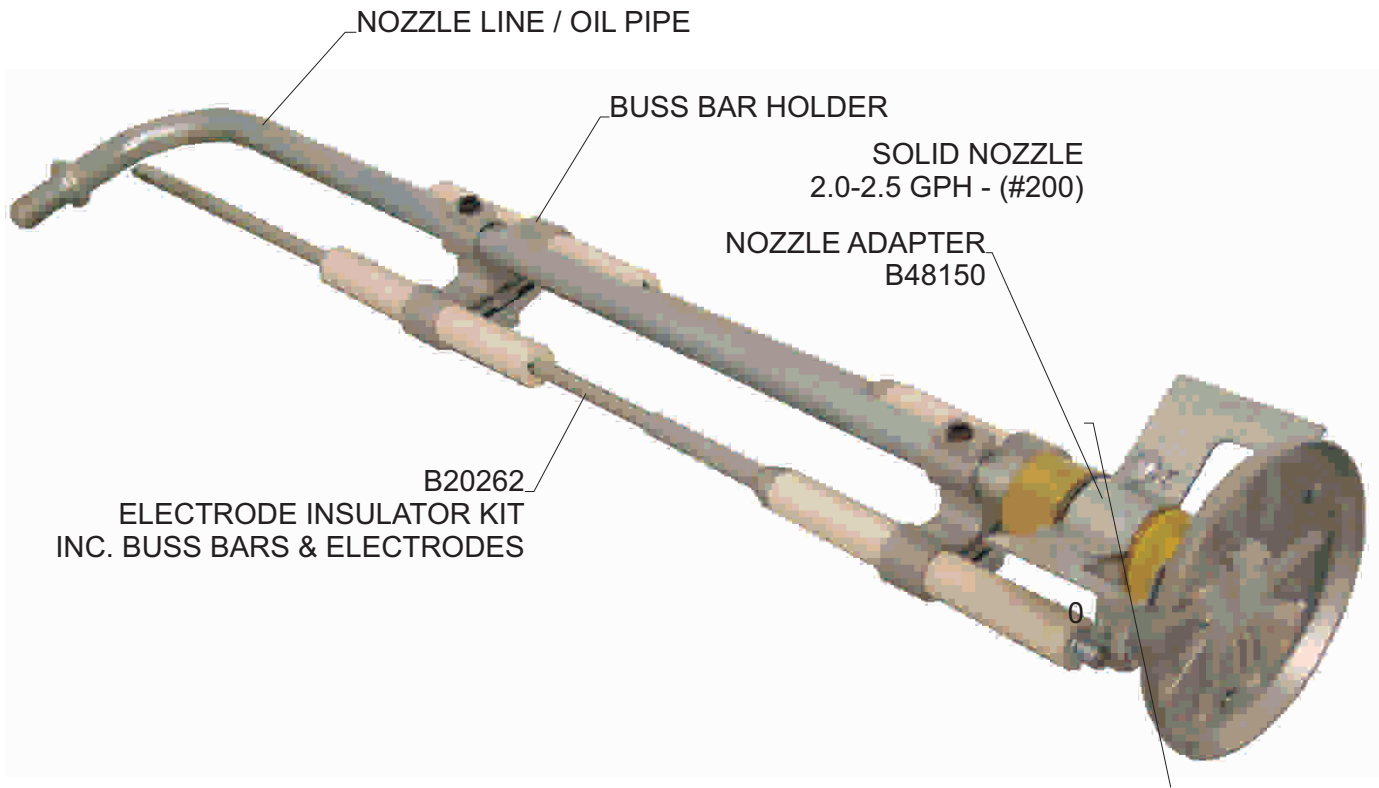

“A” PUMP (#48139) FOR IDF350-II & ALL IDF500

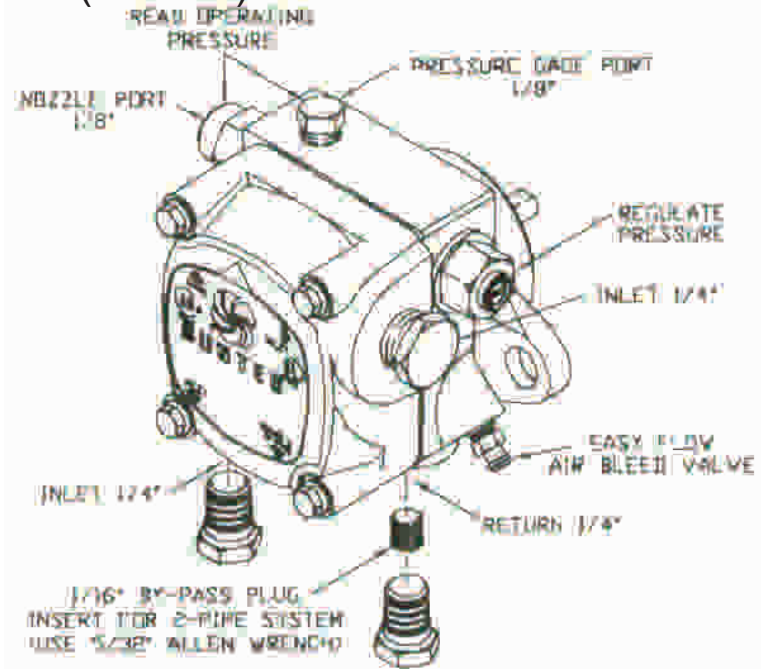

When replacing a fuel pump, ensure 1/16" by pass plug is installed in return port. Use a 5/32" allen wrench.

IDF350-II & IDF500 BURNER COMPONENTS

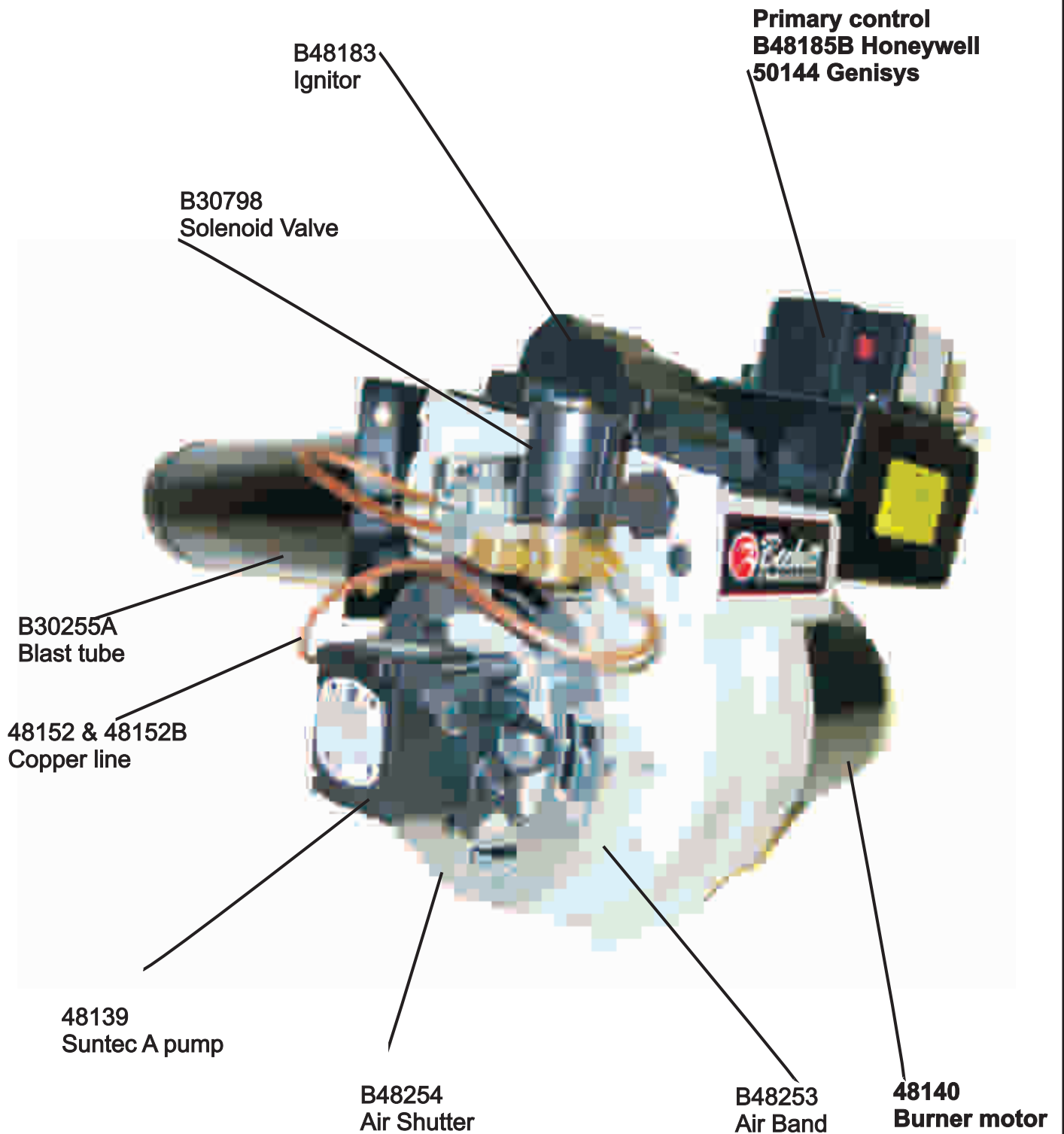

SLIDE PLATE ADJUSTMENTS OHV200 (CF)

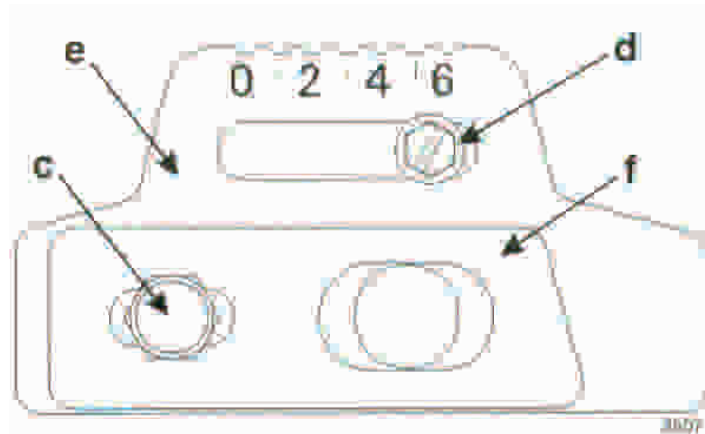

Legend

- C Acorn nut
- D Fastener
- E Indicator adjusting plate
- F Secondary adjusting plate

OHV#200 (CF)-----2

OHV350/500 (SF)-----5

ELECTRODE ADJUSTMENTS FOR CF (OHV#200))

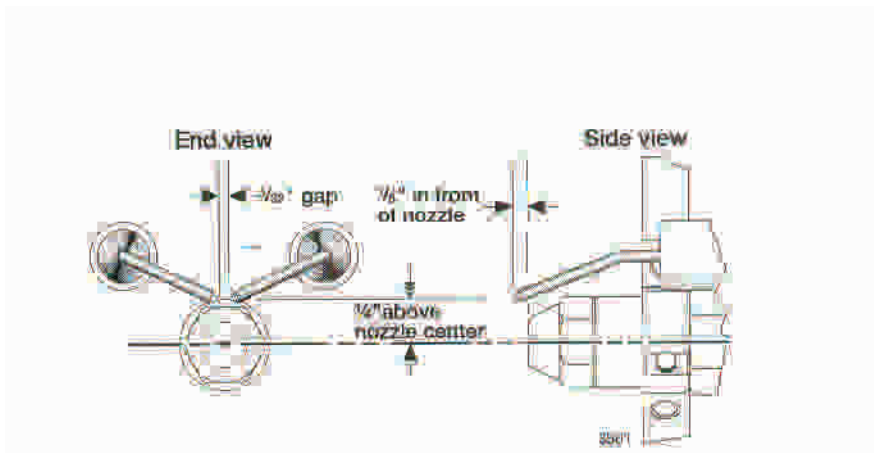

LIMITS, FAN SWITCHES AND TEMPERATURE FEELERS

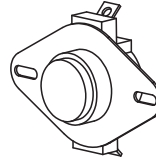
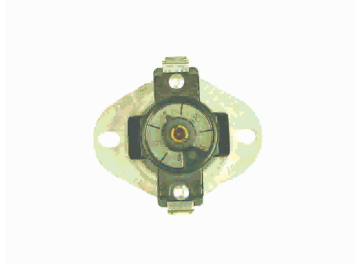

ADJUSTABLE FAN SWITCH 90-130°F (848111B)
ALL MODELS

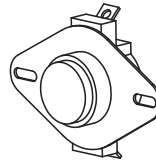

OHV HIGH LIMIT
C9648
HIGH LIMIT L220 - 40F
(848110A)



FEELER
OHV - 600
(848171)

Indoor and outdoor settings of fan switch

Indoors & if surrounding air is warm i.e. -5C/23F-Fan switch should be set to 115' or higher so as to shut down unit when heat exchanger is properly cooled, also keeps fan motor from excessive running on when discharging cooler air.

Outdoor-Fan switch should be set between 100'-90'. The colder the temperature the lower the setting.

HEAT EXCHANGER FOR OIL UNITS

P/N 48200-OHV350 & 500 OIL

P/N 20200-OHV200 OIL

L

COMBUSTION CHAMBER ASSEMBLY C/W INNER SHELL

P/N 48207-OHV350 & 500

P/N 20207-OHV200

FLUE COLLAR ASSEMBLY

P/N 48113-ALL UNITS

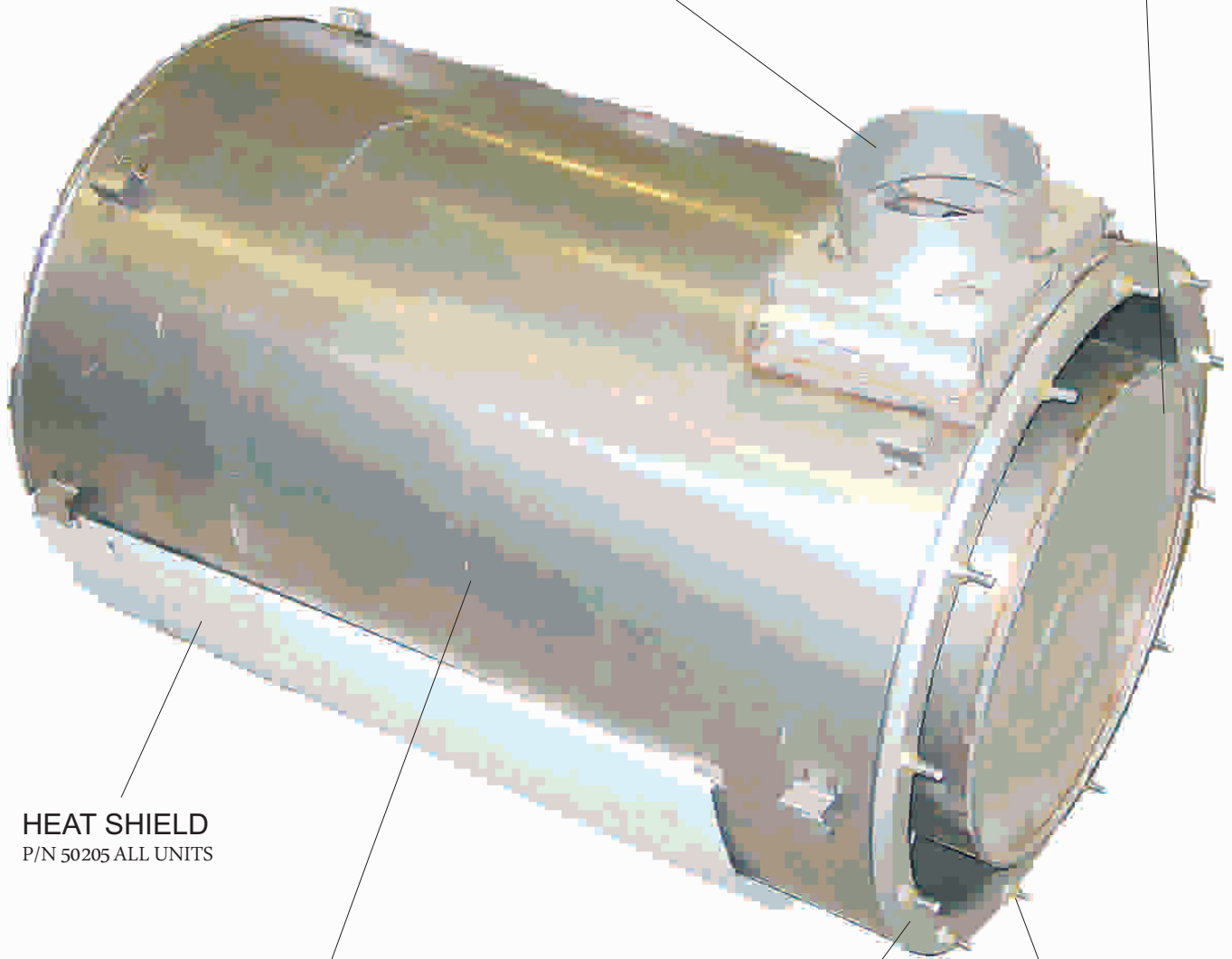

HEAT SHIELD
P/N 50205 ALL UNITS

OUTER SHELL
P/N 48206-OHV350 & 500
P/N 20206-OHV200

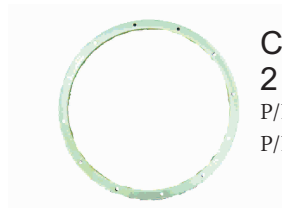

CAP RING
2 PER ASSEMBLY
P/N 48115 OHV350 & 500
P/N 50115 OHV200

RETAINER BOLT
W/WASHER
24 PER UNIT
P/N 48116 ALL UNITS



***COMBUSTION CHAMBER ASSEMBLY & INNER SHELL ALL ONE PIECE**

IDF350/500 front view



IDF350-II/500 back view

